

HINGE
SERIES

PIVOT-PRO

PIVOT-PRO



Perfect motion for every single space

Door Closing-Soft and Smooth



- The well-made DTC integrated soft-close hinges fit with a plenty of cabinet doors, supporting and facilitating designers ideas. The hinge's effortless opening, evenly speeded soft-closing and long durability contribute to the enjoyment of the furniture users.
- 3D adjustments providing exceptional functions: without loosening one screw, up & down, in & out and side to side adjustments are done.



Quietness



Intelligence



Durability



Eco-Friendliness



PIVOT-PRO combines an elegant appearance with durable components, including an integrated damping system to ensure effortless opening and smooth soft-closing of doors.

DTC
Global Quality Benchmark

HINGE SERIES PIVOT-PRO



A full range of standard and special application hinges provides options for various styles of cabinets and furniture. The new titanium black and titanium gold finish options provide a high fashion appearance as well as additional corrosion resistance.



PRODUCT



DESCRIPTION

- Opening angle: 110°
- Depth of hinge cup: 11.5mm
- Diameter of hinge cup: 35mm
- Range of door thickness: 16-26mm
- Possible drilling distances on the door(K): 3-6 mm

APPLICATION

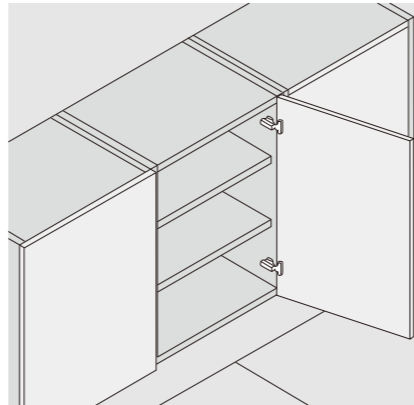

PLANNING

Space needed to open the door

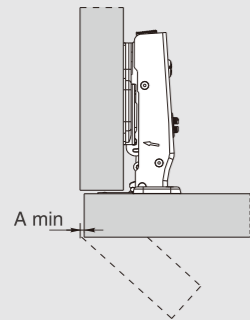

	T=	16	17	18	19	20	21	22	23	24	25	26
K=3	A=	0.7	0.9	1.2	1.5	1.8	2.2	2.6	3.2	3.8	4.5	5.3
K=4	A=	0.7	0.9	1.1	1.4	1.8	2.1	2.5	3.0	3.5	4.4	4.9
K=5	A=	0.6	0.9	1.1	1.4	1.7	2.0	2.4	2.9	3.4	3.9	4.6
K=6	A=	0.6	0.8	1.1	1.3	1.6	2.0	2.4	2.8	3.2	3.8	4.4

Space needed to open the door

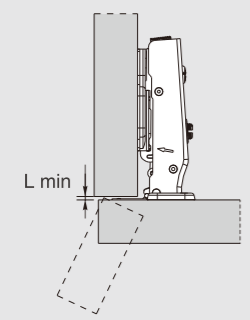

	T=	16	17	18	19	20	21	22	23	24	25	26
K=3	L=	0.0	0.0	0.0	0.0	0.0	0.0	0.0	0.0	0.0	0.0	0.1
K=4	L=	0.0	0.0	0.0	0.0	0.0	0.0	0.2	0.4	0.7	0.9	1.1
K=5	L=	0.0	0.2	0.4	0.6	0.8	1.0	1.2	1.4	1.6	1.8	2.0
K=6	L=	0.9	1.2	1.4	1.6	1.8	2.0	2.2	2.4	2.6	2.8	3.0

- The above values are calculated on the assumption that the doors have square edges.
- They are reduced if the doors have radiused edges.

Projection of the door

Projection of the door from the cabinet side at the max opening. The figures are based on a straight arm hinge, H=0mm mounting plate and drilling distance (K) =3mm.

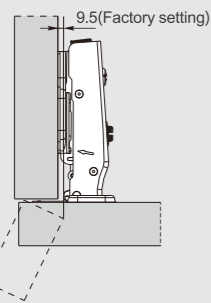

"C" value

$$C=20+K+A$$

With this formula you can obtain the max thickness of the moulded door that can be opened without touching adjacent carcass sides, doors or walls, whilst bearing in mind the above L-K-T values.

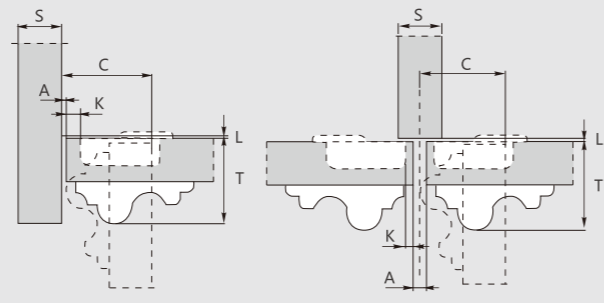

ORDER INFORMATION



Φ 35mm Options of screws and dowels:

M10 dowel Dowel No: M	Expandable dowel Dowel No: K
M8 dowel Dowel No: N	Expandable dowel Dowel No: K0
Euro screw Dowel No: B	Quick dowel Dowel No: T0

Φ 35mm Hinge cup types

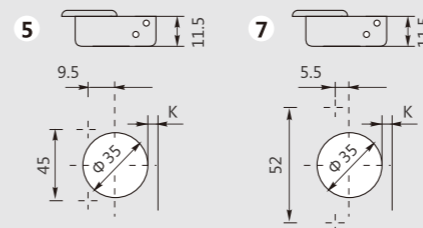

Use these formulas to determine the type of hinge arm, the drilling distance "K" and the height of the mounting plate "H" for each door application.

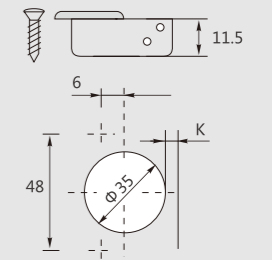

Nickel plated(A01) Titanium black(A08)

C80 Series 110° snap-on cam-adjustable soft-close hinges

Full overlay C=0



H=12+K-(D)
(Factory setting)

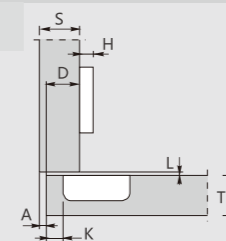

	Item No.	Pcs/ctn
Soft-close	C80A676F	200
Sprung	C80A676	200

Half overlay C=9

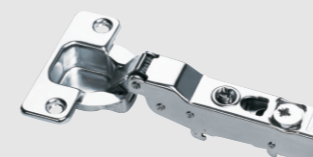

H=3+K-(D)
(Factory setting)

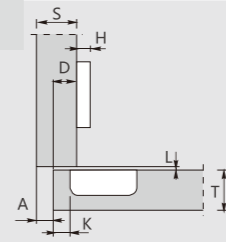

	Item No.	Pcs/ctn
Soft-close	C80B676F	200
Sprung	C80B676	200

Inset C=18



H=6+K+(A)
(Factory setting)

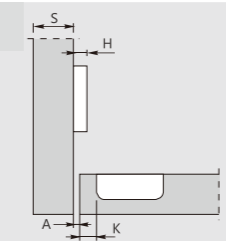

	Item No.	Pcs/ctn
Soft-close	C80C676F	200
Sprung	C80C676	200

PIVOT-PRO

C80 Series 110° Snap-on Cam-adjustable Soft-close Aluminum Frame Hinges



PRODUCT



DESCRIPTION

- Opening angle: 110°
- Drilling dimension on aluminium frame hinge head: 28mm
- Range of width of aluminium frame (V) : 19-22mm

APPLICATION

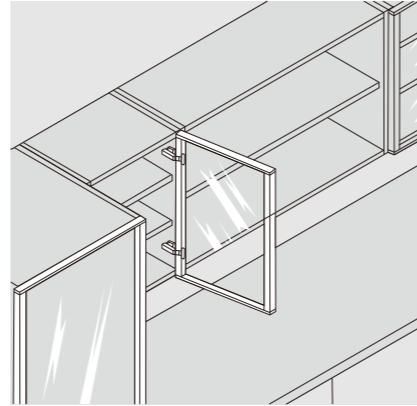

PLANNING

Space needed to open the door

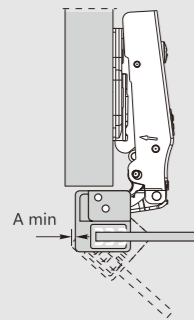

	T=	16	17	18	19	20	21	22	23	24	25	26
V=19	A=	0.7	0.9	1.2	1.5	1.8	2.2	2.6	3.2	3.8	4.5	5.3
V=20	A=	0.7	0.9	1.1	1.4	1.8	2.1	2.5	3.0	3.5	4.4	4.9
V=21	A=	0.6	0.9	1.1	1.4	1.7	2.0	2.4	2.9	3.4	3.9	4.6
V=22	A=	0.6	0.8	1.1	1.3	1.6	2.0	2.4	2.8	3.2	3.8	4.4

ORDER INFORMATION



Drilling dimensions on aluminium frame

V:19mm-22mm

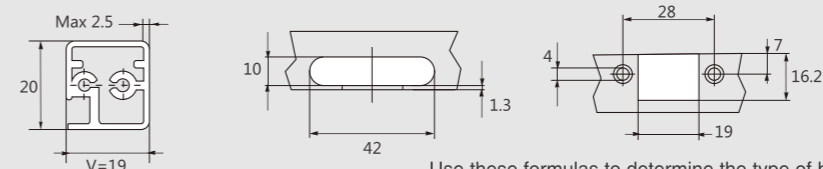

Use these formulas to determine the type of hinge arm, the drilling distance "K" and the height of the mounting plate "H" for each door application.

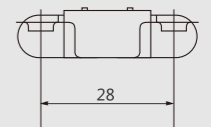

Nickel plated(A01)

Titanium black(A08)

Space needed to open the door

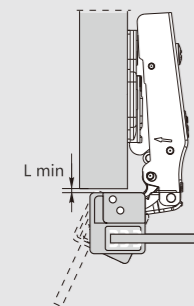

	T=	16	17	18	19	20	21	22	23	24	25	26
V=19	L=	0.0	0.0	0.0	0.0	0.0	0.0	0.0	0.0	0.0	0.0	0.1
V=20	L=	0.0	0.0	0.0	0.0	0.0	0.0	0.2	0.4	0.7	0.9	1.1
V=21	L=	0.0	0.2	0.4	0.6	0.8	1.0	1.2	1.4	1.6	1.8	2.0
V=22	L=	0.9	1.2	1.4	1.6	1.8	2.0	2.2	2.4	2.6	2.8	3.0

- The above values are calculated on the assumption that the doors have square edges.
- They are reduced if the doors have radiused edges.

C80 Series 110° snap-on cam-adjustable soft-close aluminum frame hinges

Full overlay C=0



H=-2+V-(D)

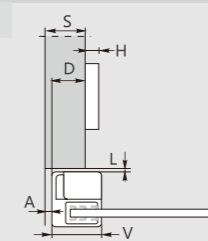

	Item No.	Pcs/ctn
Soft-close	C80A678F	200
Sprung	C80A678	200

Half overlay C=9



H=-11+V-(D)

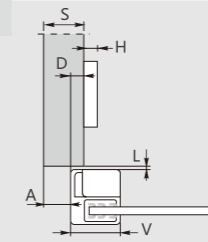

	Item No.	Pcs/ctn
Soft-close	C80B678F	200
Sprung	C80B678	200

Inset C=18



H=-20.5+V+(A)

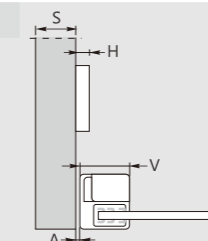

	Item No.	Pcs/ctn
Soft-close	C80C678F	200
Sprung	C80C678	200

C=0 Application with full overlay door

D=18mm

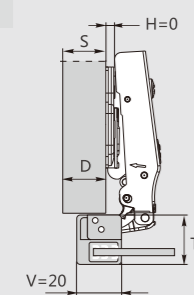

C=9 Application with half overlay door

D=9mm

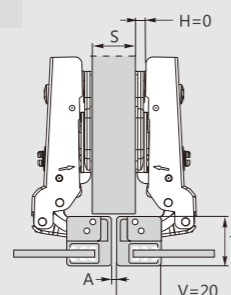

C=18 Application with inset door

A=0.5mm

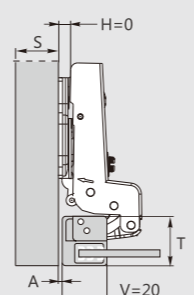

PIVOT-PRO

C80 Series Snap-on Cam-adjustable Angled Hinges



PRODUCT



DESCRIPTION

- Opening angle: 55°
- Depth of hinge cup: 11.5mm
- Diameter of hinge cup: 35mm
- Range of door thickness: 14-26mm
- Possible drilling distances on the door(K): 3-7 mm

APPLICATION

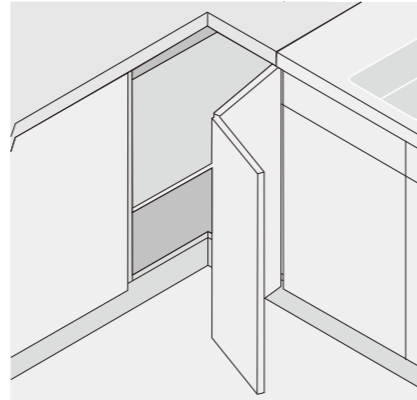

ORDER INFORMATION



Options of screws and dowels:

M10 dowel Dowel No: M	Expandable dowel Dowel No: K
M8 dowel Dowel No: N	Expandable dowel Dowel No: K0
Euro screw Dowel No: B	Quick dowel Dowel No: T0

Φ 35MM CORNER DOOR, BI-FOLD DOOR, -45°~45° ANGLED HINGE APPLICATIONS

Kitchen corner door applications

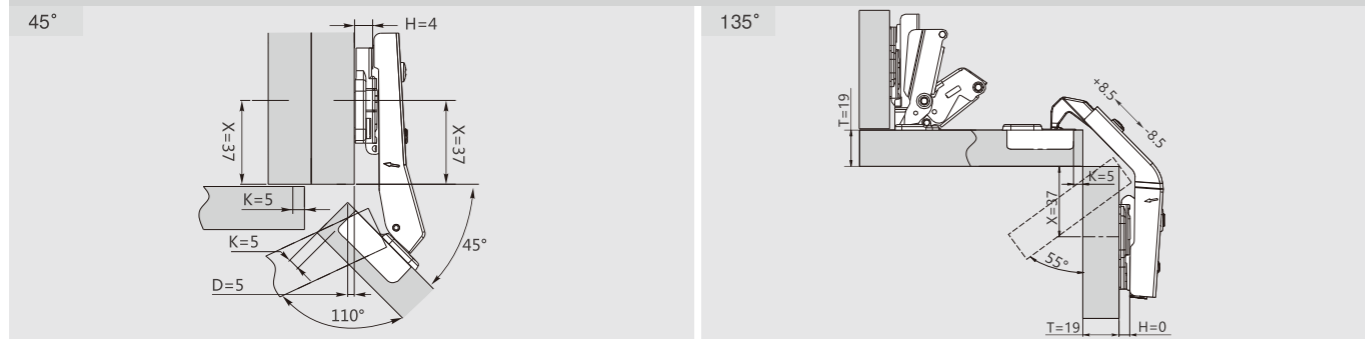

Negative angled hinge applications

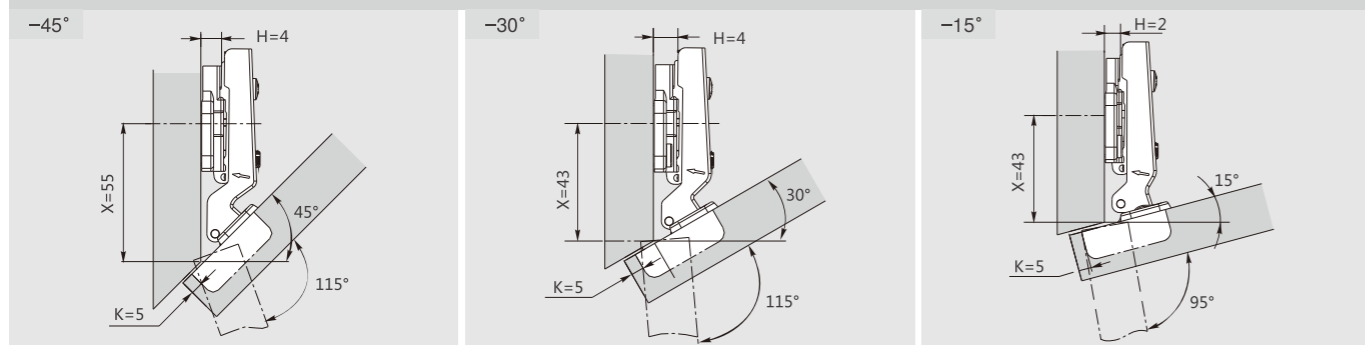

Positive angled hinge applications

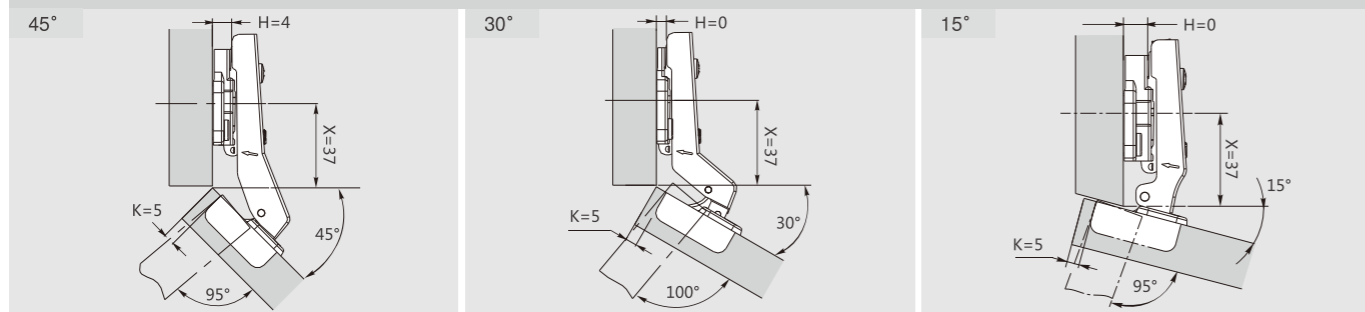

The solution of assembly problems where doors are mounted at a positive or negative angle requires the verification of drilling distances by a practical trial. Please do not hesitate to consult our technical support department for assistance.

Nickel plated(A01) Titanium black(A08)

C80 Series snap-on cam-adjustable angled hinges

T=Door thickness D=Required door overlay H=Height of the mounting plate
X=Distance from bottom plate screw hole to plate edge K=Drilling distance
L=Gap between door and carcass

Adjustment range of D: -3 → +3

Adjustment range of L: -3 → +3

Door thickness	Mounting plate height
14 ≤ T < 19	H=2
T=19	H=2
19 < T ≤ 26	H=0

Item No.	Pcs/ctn
Spring C80H676	200



PRODUCT



DESCRIPTION

- Opening angle: 110°
- Depth of hinge cup: 11.5mm
- Diameter of hinge cup: 35mm
- Range of door thickness: 16-26mm
- Possible drilling distances on the door(K): 3-6 mm

APPLICATION

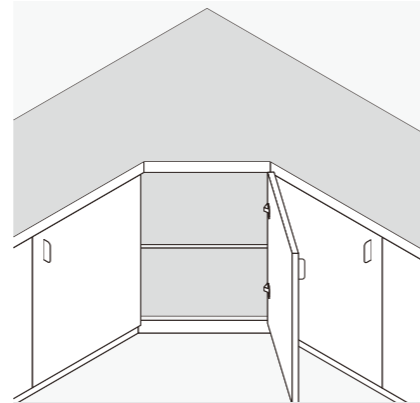

PLANNING

Space needed to open the door

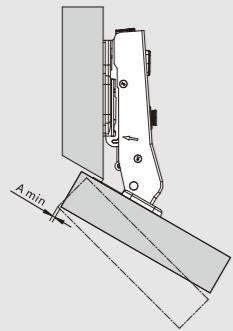

	T=	14	15	16	17	18	19	20	21	22	23	24
K=3	A=	0.3	0.5	0.7	0.9	1.2	1.5	1.8	2.2	2.6	3.1	3.8
K=3	A=	0.3	0.5	0.7	0.9	1.1	1.4	1.7	2.1	2.5	3.0	3.5
K=3	A=	0.3	0.5	0.7	0.9	1.1	1.4	1.7	2.0	2.4	2.9	3.4
K=3	A=	0.3	0.5	0.6	0.8	1.1	1.3	1.6	2.0	2.3	2.8	3.2
K=3	A=	0.3	0.4	0.6	0.8	1.0	1.3	1.6	1.9	2.3	2.7	3.1
K=3	A=	0.3	0.4	0.6	0.8	1.0	1.3	1.5	1.9	2.2	2.6	3.0

- T=Door thickness
- K=Cup hole drilling distance from door edge

Space needed to open the door

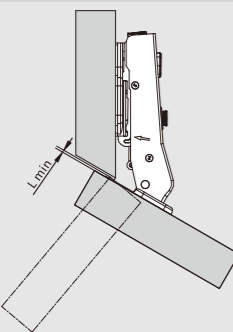

	T=	14	15	16	17	18	19	20	21	22	23	24
K=3	L=	0.0	0.0	0.0	0.0	0.0	0.0	0.0	0.0	0.0	0.0	0.0
K=3	L=	0.0	0.0	0.0	0.0	0.0	0.0	0.0	0.0	0.0	0.0	0.1
K=3	L=	0.0	0.0	0.0	0.0	0.1	0.3	0.4	0.6	0.8	1.0	1.1
K=3	L=	0.4	0.6	0.7	0.9	1.1	1.2	1.4	1.6	1.8	1.9	2.1
K=3	L=	1.4	1.5	1.7	1.9	2.1	2.2	2.4	2.6	2.8	2.9	3.1
K=3	L=	2.4	2.5	2.7	2.9	3.0	3.2	3.4	3.6	3.7	3.9	4.1

- The above values are calculated on the assumption that the doors have square edges.
- They are reduced if the doors have radiused edges.

ORDER INFORMATION

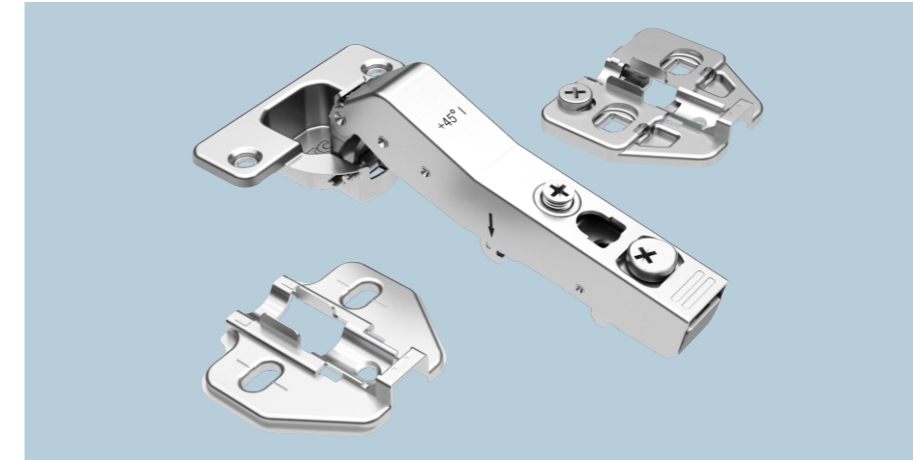

Φ 35mm Options of screws and dowels:

M10 dowel Dowel No: M	Expandable dowel Dowel No: K
M8 dowel Dowel No: N	Expandable dowel Dowel No: K0
Euro screw Dowel No: B	Quick dowel Dowel No: T0

Φ 35mm Hinge cup types

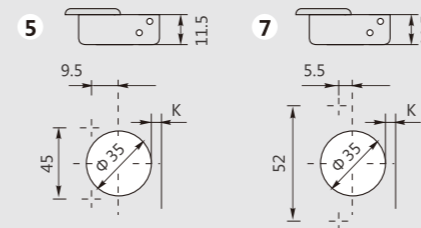

The solution of assembly problems where doors are mounted at a positive or negative angle requires the verification of drilling distances by a practical trial. Please do not hesitate to consult our technical support department for assistance.

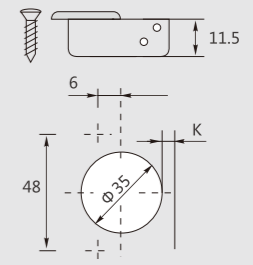

Nickel plated(A01) Titanium black(A08)

C80 Series snap-on cam-adjustable soft-close 30° angled hinges

Overlay 30°

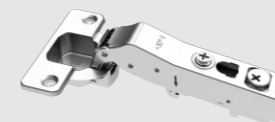

C80 Series snap-on cam-adjustable soft-close 45° angled hinges

Small Overlay 45°

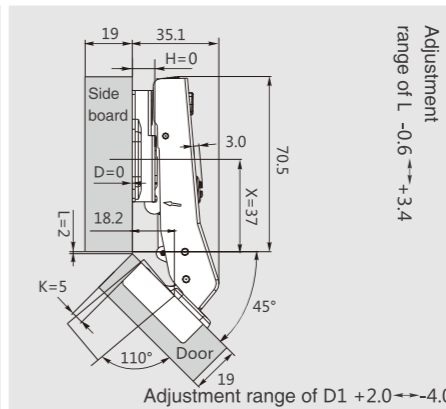
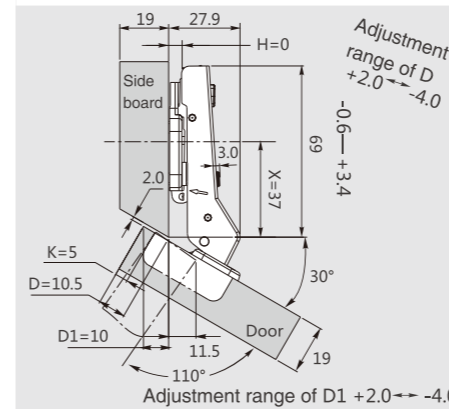

	Item No.	Pcs/ctn	Item No.	Pcs/ctn	
Soft-close	C80W676F	200	Soft-close	C80E676F	200
Sprung	C80W676	200	Sprung	C80E676	200



PRODUCT



DESCRIPTION

- Opening angle: 110°
- Depth of hinge cup: 11.5mm
- Diameter of hinge cup: 35mm
- Range of door thickness: 16-26mm
- Possible drilling distances on the door(K): 3-6 mm

APPLICATION

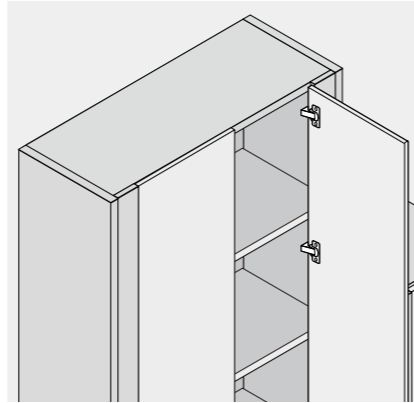

PLANNING

Space needed to open the door

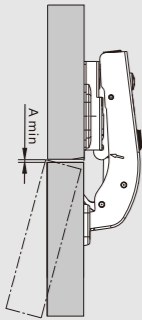

	T=	14	15	16	17	18	19	20	21	22	23	24
K=3	A=	0.3	0.5	0.7	0.9	1.2	1.5	1.8	2.2	2.6	3.1	3.8
K=3	A=	0.3	0.5	0.7	0.9	1.1	1.4	1.7	2.1	2.5	3.0	3.5
K=3	A=	0.3	0.5	0.7	0.9	1.1	1.4	1.7	2.0	2.4	2.9	3.4
K=3	A=	0.3	0.5	0.6	0.8	1.1	1.3	1.6	2.0	2.3	2.8	3.2
K=3	A=	0.3	0.4	0.6	0.8	1.0	1.3	1.6	1.9	2.3	2.7	3.1
K=3	A=	0.3	0.4	0.6	0.8	1.0	1.3	1.5	1.9	2.2	2.6	3.0

- T=Door thickness
- K=Cup hole drilling distance from door edge

Space needed to open the door

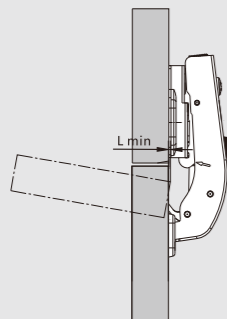

	T=	14	15	16	17	18	19	20	21	22	23	24
K=3	L=	0.0	0.0	0.0	0.0	0.0	0.0	0.0	0.0	0.0	0.0	0.0
K=3	L=	0.0	0.0	0.0	0.0	0.0	0.0	0.0	0.0	0.0	0.0	0.1
K=3	L=	0.0	0.0	0.0	0.0	0.1	0.3	0.4	0.6	0.8	1.0	1.1
K=3	L=	0.4	0.6	0.7	0.9	1.1	1.2	1.4	1.6	1.8	1.9	2.1
K=3	L=	1.4	1.5	1.7	1.9	2.1	2.2	2.4	2.6	2.8	2.9	3.1
K=3	L=	2.4	2.5	2.7	2.9	3.0	3.2	3.4	3.6	3.7	3.9	4.1

- The above values are calculated on the assumption that the doors have square edges.
- They are reduced if the doors have radiused edges.

ORDER INFORMATION

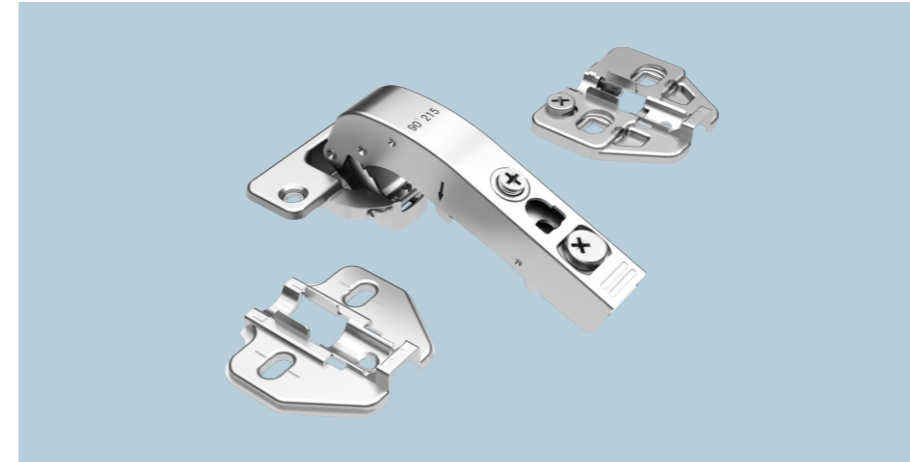

Φ 35mm Options of screws and dowels:

M10 dowel Dowel No: M	Expandable dowel Dowel No: K
M8 dowel Dowel No: N	Expandable dowel Dowel No: K0
Euro screw Dowel No: B	Quick dowel Dowel No: T0

Φ 35mm Hinge cup types

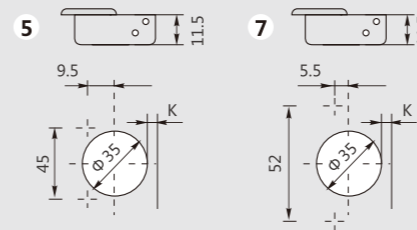

The solution of assembly problems where doors are mounted at a positive or negative angle requires the verification of drilling distances by a practical trial. Please do not hesitate to consult our technical support department for assistance.

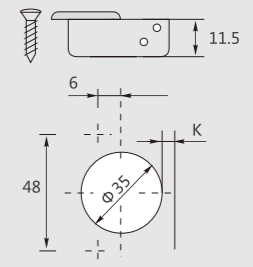

Nickel plated(A01) Titanium black(A08)

C80 Series snap-on cam-adjustable soft-close angled hinges

90°



90°

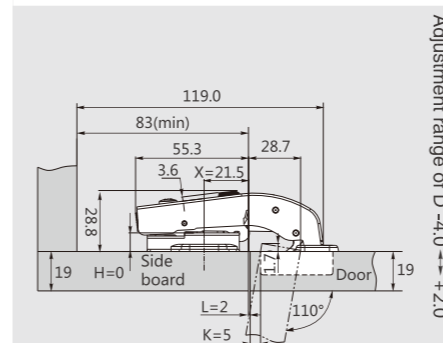

Adjustment range of L -0.6 ↔ +3.4

	Item No.	Pcs/ctn
Soft-close	C80J676F	200
Sprung	C80J676	200

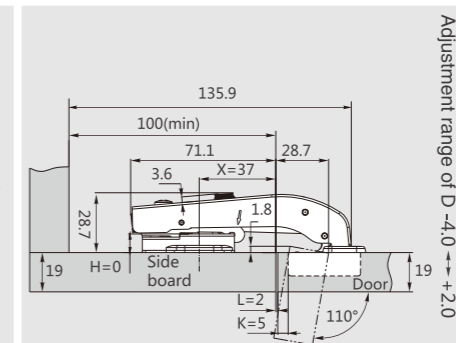

Adjustment range of L -0.6 ↔ +3.4

	Item No.	Pcs/ctn
Soft-close	C80G676F	200
Sprung	C80G676	200

PIVOT-PRO

C80 Series 155° Snap-on Cam-adjustable Soft-close Hinges



PRODUCT



DESCRIPTION

- Opening angle: 155°
- Depth of hinge cup: 11.5mm
- Diameter of hinge cup: 35mm
- Range of door thickness: 16-24mm
- Possible drilling distances on the door(K): 3-6 mm

APPLICATION

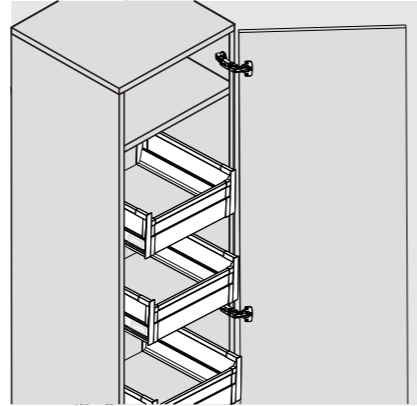

PLANNING

Space needed to open the door

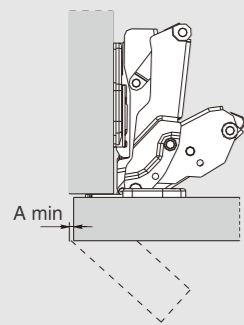

	T=	16	17	18	19	20	21	22	23	24		
K=3	A=	0	0	0	0	0	0	0	0	0		
K=4	A=	0	0	0	0	0	0	0	0	0		
K=5	A=	0	0	0	0	0	0	0	0	0		
K=6	A=	0	0	0	0	0	0	0	0	0		

Application

The door combined with a mounting plate H=0, opens at 90° with a 2.3mm protrusion allowing objects (e.g. drawers) move from inside of the cabinet.

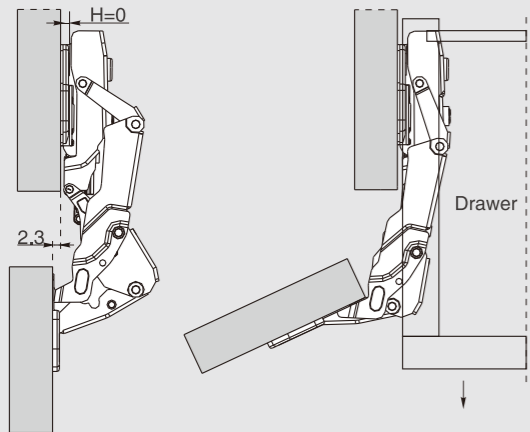

Full overlay C=0

No gap is required when door thickness is less than 24mm. A trial assembly is recommended when door thickness is more than 24mm.

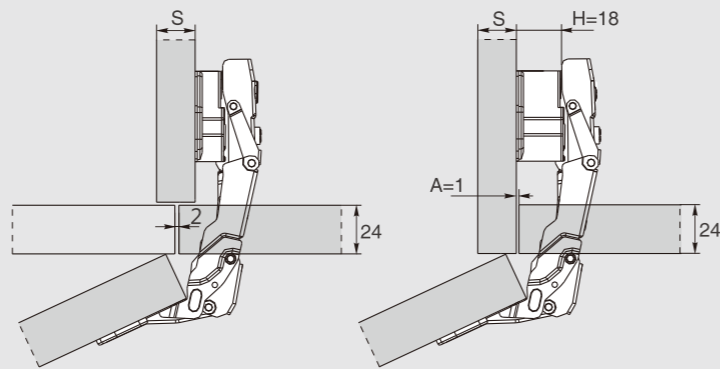

Half overlay C=9

Inset C=18

ORDER INFORMATION

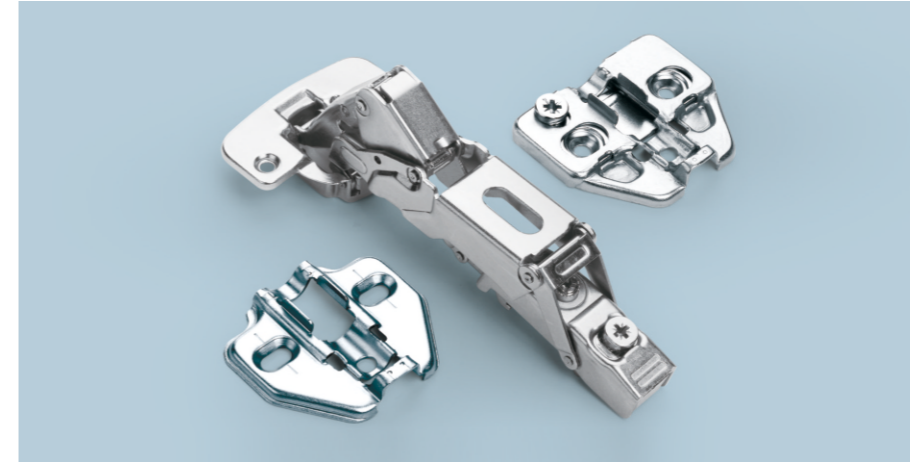

Φ 35mm Options of screws and dowels:

M10 dowel Dowel No: M	Expandable dowel Dowel No: K0
M8 dowel Dowel No: N	Quick dowel Dowel No: T0
Expandable dowel Dowel No: K	

Φ 35mm Hinge cup types

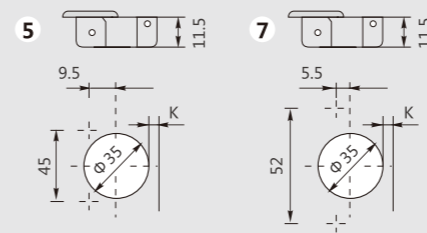

Use these formulas to determine the type of hinge arm, the drilling distance "K" and the height of the mounting plate "H" for each door application.

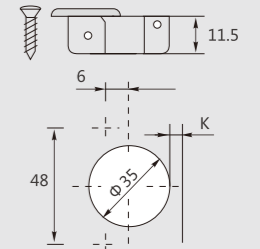

Nickel plated(A01) Titanium black(A08)

C80 Series 155° snap-on cam-adjustable soft-close hinges

Full overlay C=0		Small overlay C=4		Half overlay C=9		Inset C=18	
H=11+K-(D)		H=11+K-(D)		H=11+K-(D)		H=11+K+(A)	
K=5, for full overlay D=16±2mm, H=0 mounting plate only		K=5, for small overlay D=12±2mm, H=4 mounting plate only		K=5, for half overlay D=7±2mm, H=9 mounting plate only		K=5, for inset door, H=18 mounting plate only	
Item No.	Pcs/ctn	Item No.	Pcs/ctn	Item No.	Pcs/ctn	Item No.	Pcs/ctn
Soft-close C80A606F	100	Soft-close C80A606F	100	Soft-close C80A606F	100	Soft-close C80A606F	100
Sprung C80A606	100	Sprung C80A606	100	Sprung C80A606	100	Sprung C80A606	100

PIVOT-PRO

C80 Series 95° Snap-on Cam-adjustable Soft-close Hinges for Thick Door



PRODUCT



DESCRIPTION

- Opening angle: 95°
- Depth of hinge cup: 11.5mm
- Diameter of hinge cup: 35mm
- Range of door thickness: 19-35mm
- Possible drilling distances on the door(K): 3-9 mm

APPLICATION

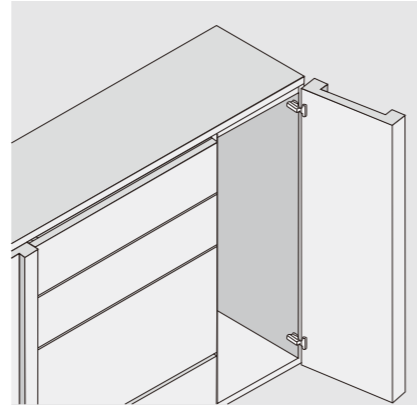

PLANNING

Space needed to open the door

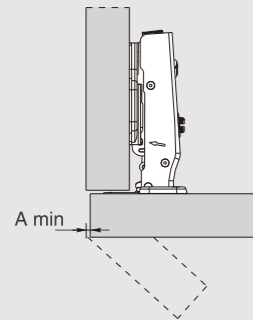

T=	19	20	21	22	23	24	25	26	27	28	29	30	31	32 - 35
K=3 A=	0.1	0.2	0.3	0.4	0.5	0.7	0.9	1.3	2.2	3.2	4.1	5.0	6.0	7.0 - 10
K=4 A=	0.1	0.2	0.3	0.4	0.5	0.7	0.8	1.0	1.6	2.5	3.5	4.4	5.3	6.3 - 9.1
K=5 A=	0.1	0.2	0.3	0.4	0.5	0.7	0.8	1.0	1.2	2.0	2.9	3.7	4.7	5.6 - 8.4
K=6 A=	0.1	0.2	0.3	0.4	0.5	0.6	0.8	1.0	1.2	1.4	2.3	3.2	4.1	5.0 - 7.8
K=7 A=	0.1	0.2	0.3	0.4	0.5	0.6	0.8	1.0	1.2	1.4	1.8	2.7	3.6	4.4 - 7.0
K=8 A=	0.1	0.2	0.3	0.4	0.5	0.6	0.8	1.0	1.1	1.4	1.6	2.2	3.1	3.9 - 6.5
K=9 A=	0.1	0.2	0.3	0.4	0.5	0.6	0.8	0.9	1.1	1.3	1.6	1.8	2.6	3.4 - 6.0

Space needed to open the door

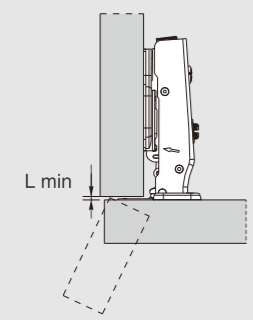

T=	19	20	21	22	23	24	25	26	27	28	29	30	31	32 - 35
K=3 L=	0.0	0.0	0.0	0.0	0.0	0.0	0.0	0.0	0.0	0.0	0.0	0.0	0.0	0.0 - 0.0
K=4 L=	0.0	0.0	0.0	0.0	0.0	0.0	0.0	0.0	0.0	0.0	0.0	0.0	0.0	0.0 - 0.0
K=5 L=	0.0	0.0	0.0	0.0	0.0	0.0	0.0	0.0	0.0	0.2	0.2	0.3	0.4	0.5 - 0.7
K=6 L=	0.3	0.4	0.5	0.6	0.7	0.7	0.8	0.9	1.0	1.2	1.2	1.3	1.4	1.5 - 1.7
K=7 L=	1.3	1.4	1.5	1.6	1.7	1.7	1.8	1.9	2.0	2.2	2.2	2.3	2.4	2.5 - 2.7
K=8 L=	2.3	2.4	2.5	2.6	2.7	2.7	2.8	2.9	3.0	3.2	3.2	3.3	3.4	3.5 - 3.7
K=9 L=	3.3	3.4	3.5	3.6	3.7	3.7	3.8	3.9	4.0	4.2	4.2	4.3	4.4	4.5 - 4.7

- The above values are calculated on the assumption that the doors have square edges.
- They are reduced if the doors have radiused edges.

Projection of the door

Projection of the door from the cabinet side at the max opening. The figures are based on a straight arm hinge, H=0mm mounting plate and drilling distance (K) =3mm.

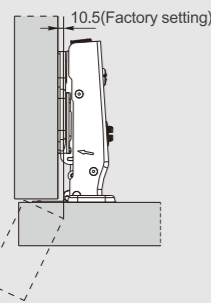

"C" value

$$C=22+K+A$$

With this formula you can obtain the max thickness of the moulded door that can be opened without touching adjacent carcass sides, doors or walls, whilst bearing in mind the above L-K-T values.

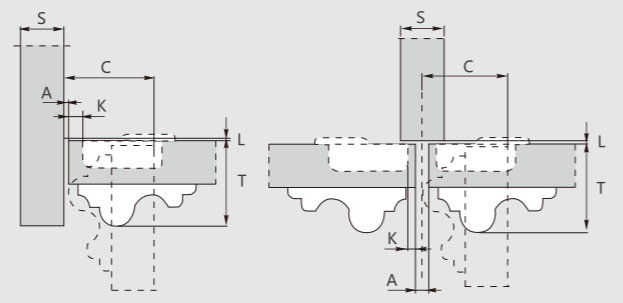

ORDER INFORMATION



Φ 35mm Options of screws and dowels:

M10 dowel Dowel No: M	Expandable dowel Dowel No: K
M8 dowel Dowel No: N	Expandable dowel Dowel No: K0
Euro screw Dowel No: B	Quick dowel Dowel No: T0

Φ 35mm Hinge cup types

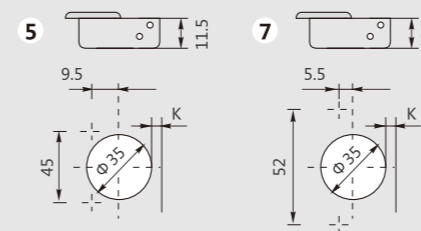

Use these formulas to determine the type of hinge arm, the drilling distance "K" and the height of the mounting plate "H" for each door application.

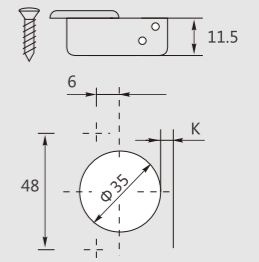

Nickel plated(A01) Titanium black(A08)

C80 Series 95° snap-on cam-adjustable soft-close hinges for thick door

Full overlay C=0



$$H=12+K-(D)$$

(Factory setting)

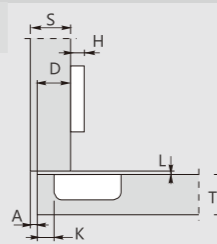

	Item No.	Pcs/ctn
Soft-close	C80A616F	200
Sprung	C80A616	200

Half overlay C=9



$$H=3+K-(D)$$

(Factory setting)

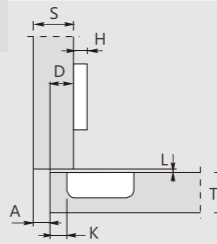

	Item No.	Pcs/ctn
Soft-close	C80B616F	200
Sprung	C80B616	200

Inset C=18



$$H=-6+K+(A)$$

(Factory setting)

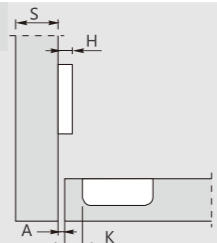

	Item No.	Pcs/ctn
Soft-close	C80C616F	200
Sprung	C80C616	200

PIVOT-PRO

C80 Series $\Phi 40$ 95° Snap-on Cam-adjustable Soft-close Hinges for Thick Door



PRODUCT



DESCRIPTION

- Opening angle: 95°
- Depth of hinge cup: 13mm
- Diameter of hinge cup: 40mm
- Range of door thickness: 20-40mm
- Possible drilling distances on the door(K): 3-15 mm

APPLICATION

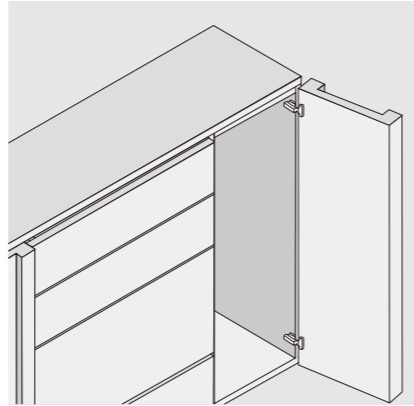

PLANNING

Space needed to open the door

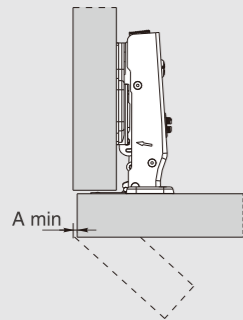

	T=	20	21	22	23	24	25	26	27	28	29	30	31	32	33 - 40
K=3	A=	0.3	0.5	0.6	0.8	1.0	1.2	1.4	1.6	1.9	2.2	2.5	2.8	3.2	3.5 - 9.7
K=4	A=	0.3	0.5	0.6	0.8	1.0	1.2	1.4	1.6	1.9	2.1	2.4	2.8	3.1	3.4 - 9.1
K=5	A=	0.3	0.5	0.6	0.8	0.9	1.1	1.4	1.6	1.8	2.1	2.4	2.7	3.0	3.4 - 8.5
K=6	A=	0.3	0.5	0.6	0.8	0.9	1.1	1.3	1.6	1.8	2.1	2.3	2.7	3.0	3.3 - 7.9
K=7	A=	0.3	0.4	0.6	0.7	0.9	1.1	1.3	1.5	1.8	2.0	2.3	2.6	2.9	3.3 - 7.3
K=8	A=	0.3	0.4	0.6	0.7	0.9	1.1	1.3	1.5	1.7	2.0	2.3	2.6	2.9	3.2 - 6.9
		-	-	-	-	-	-	-	-	-	-	-	-	-	-
K=15	A=	0.3	0.4	0.5	0.6	0.8	1.0	1.1	1.3	1.6	1.8	2.0	2.3	2.5	2.8 - 5.4

Space needed to open the door

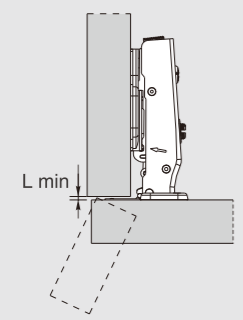

	T=	20	21	22	23	24	25	26	27	28	29	30	31	32	33 - 40
K=3-9	L=	0.0	0.0	0.0	0.0	0.0	0.0	0.0	0.0	0.0	0.0	0.0	0.0	0.0	0.0 - 0.0
K=10	L=	0.0	0.0	0.0	0.0	0.0	0.0	0.0	0.0	0.0	0.0	0.1	0.1	0.2	0.3 - 0.8
K=11	L=	0.4	0.5	0.6	0.7	0.7	0.8	0.9	0.9	1.0	1.1	1.1	1.2	1.3	1.4 - 1.8
K=12	L=	1.4	1.5	1.6	1.7	1.7	1.8	1.9	1.9	2.0	2.1	2.1	2.2	2.3	2.4 - 2.8
K=13	L=	2.4	2.5	2.6	2.7	2.7	2.8	2.9	2.9	3.0	3.1	3.1	3.2	3.3	3.3 - 3.8
K=14	L=	3.4	3.5	3.6	3.6	3.7	3.8	3.9	3.9	4.0	4.1	4.1	4.2	4.3	4.3 - 4.8
K=15	L=	4.4	4.5	4.6	4.6	4.7	4.8	4.9	4.9	5.0	5.1	5.1	5.2	5.3	5.3 - 5.8

- The above values are calculated on the assumption that the doors have square edges.
- They are reduced if the doors have radiused edges.

Projection of the door

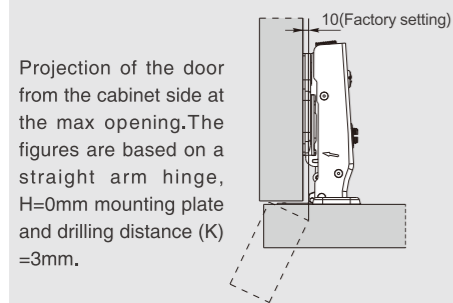

"C" value

$$C = 28 + K + A$$

With this formula you can obtain the max thickness of the moulded door that can be opened without touching adjacent carcass sides, doors or walls, whilst bearing in mind the above L-K-T values.

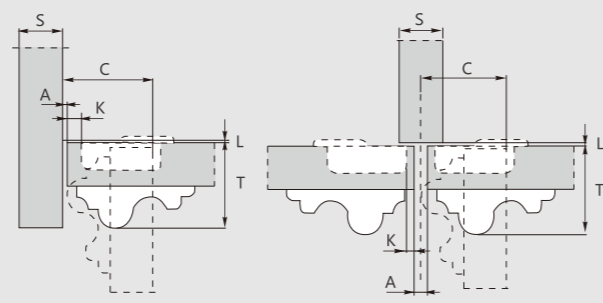

ORDER INFORMATION



$\Phi 35$ mm Options of screws and dowels:

M10 dowel Dowel No: M	Expandable dowel Dowel No: K
M8 dowel Dowel No: N	Expandable dowel Dowel No: K0
Euro screw Dowel No: B	Quick dowel Dowel No: T0

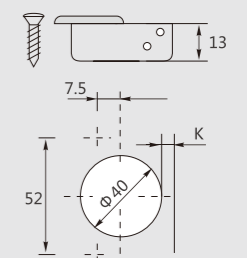

Nickel plated(A01) Titanium black(A08)

C80 Series $\Phi 40$ 95° snap-on cam-adjustable soft-close hinges for thick door

Full overlay C=0



H=18+K-(D)
(Factory setting)

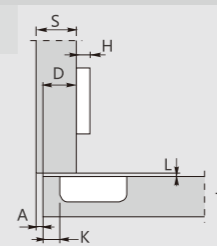

	Item No.	Pcs/ctn
Soft-close	C80A697F	200
Sprung	C80A697	200

Half overlay C=9



H=9+K-(D)
(Factory setting)

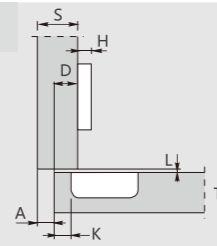

	Item No.	Pcs/ctn
Soft-close	C80B697F	200
Sprung	C80B697	200

Inset C=24



H=-6+K+(A)
(Factory setting)

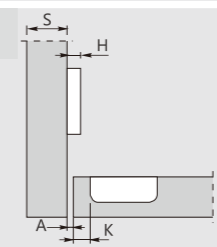

	Item No.	Pcs/ctn
Soft-close	C80C697F	200
Sprung	C80C697	200

PIVOT-PRO

C80 Series $\Phi 26$ 100° Snap-on Cam-adjustable Soft-close Hinges



PRODUCT



DESCRIPTION

- Opening angle: 100°
- Depth of hinge cup: 10mm
- Diameter of hinge cup: 26mm
- Range of door thickness: 12-22mm
- Possible drilling distances on the door(K): 3-7 mm

APPLICATION

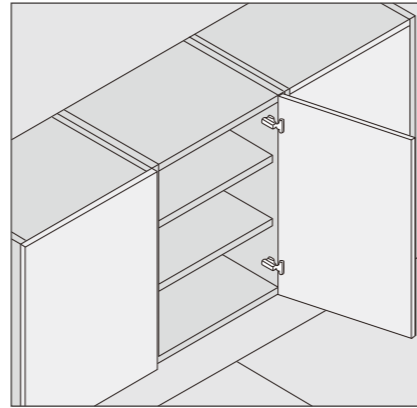

PLANNING

Space needed to open the door

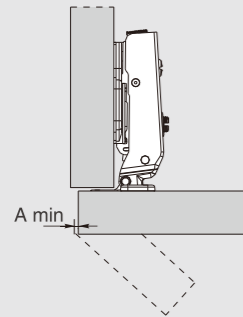

T=	12	13	14	15	16	17	18	19	20	21	22
K=3	A= 0.5	0.8	1.1	1.4	1.9	2.6	3.4	4.2	5.1	6.0	6.9
K=4	A= 0.5	0.7	1.0	1.4	1.8	2.3	3.0	3.8	4.6	5.4	6.3
K=5	A= 0.5	0.7	1.0	1.3	1.7	2.2	2.8	3.4	4.2	5.0	5.8
K=6	A= 0.4	0.6	0.9	1.2	1.6	2.0	2.5	3.2	3.9	4.6	5.4
K=7	A= 0.4	0.6	0.9	1.2	1.5	1.9	2.4	2.9	3.6	4.3	5.0

Space needed to open the door

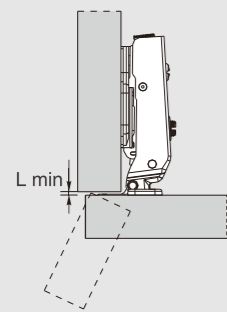

T=	12	13	14	15	16	17	18	19	20	21	22
K=3	L= 0.0	0.0	0.0	0.0	0.0	0.1	0.1	0.3	0.5	0.6	0.8
K=4	L= 0.0	0.2	0.4	0.6	0.7	0.9	1.1	1.3	1.4	1.6	1.8
K=5	L= 1.0	1.2	1.4	1.6	1.7	1.9	2.1	2.2	2.4	2.6	2.8
K=6	L= 2.0	2.2	2.4	2.5	2.7	2.9	3.1	3.2	3.4	3.6	3.8
K=7	L= 3.0	3.2	3.4	3.5	3.7	3.9	4.0	4.2	4.4	4.6	4.7

- The above values are calculated on the assumption that the doors have square edges.
- They are reduced if the doors have radiused edges.

Projection of the door

Projection of the door from the cabinet side at the max opening. The figures are based on a straight arm hinge, H=0mm mounting plate and drilling distance (K) =3mm.

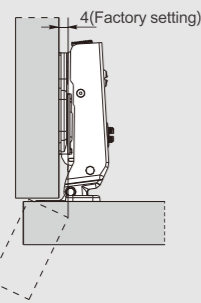

"C" value

$$C=13+K+A$$

With this formula you can obtain the max thickness of the moulded door that can be opened without touching adjacent carcass sides, doors or walls, whilst bearing in mind the above L-K-T values.

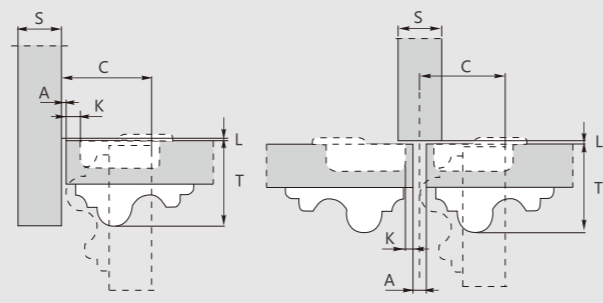

ORDER INFORMATION



$\Phi 26$ mm Options of screws and dowels:

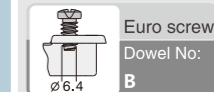
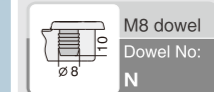
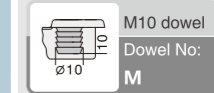

$\Phi 26$ mm Hinge cup types

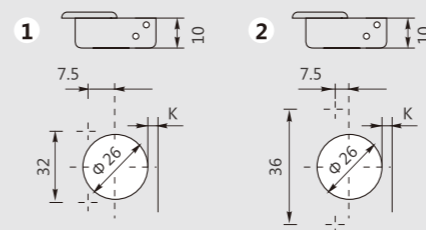

Use these formulas to determine the type of hinge arm, the drilling distance "K" and the height of the mounting plate "H" for each door application.

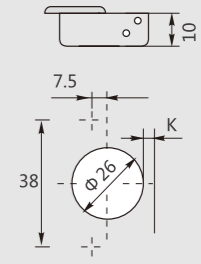

Nickel plated(A01)

Titanium black(A08)

C80 Series $\Phi 26$ 100° snap-on cam-adjustable soft-close hinges

Full overlay C=0



H=10.5+K-(D)
(Factory setting)

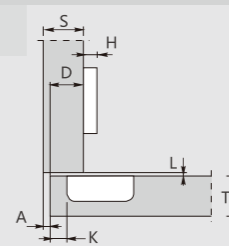

	Item No.	Pcs/ctn
Soft-close	C80A6A3F	200
Sprung	C80A6A3	200

Half overlay C=9



H=1.5+K-(D)
(Factory setting)

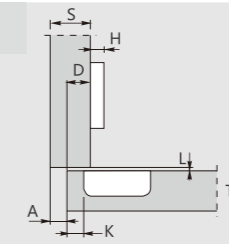

	Item No.	Pcs/ctn
Soft-close	C80B6A3F	200
Sprung	C80B6A3	200

Inset C=16.5



H=8.5+K+(A)
(Factory setting)

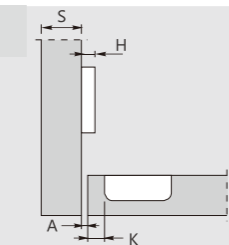

	Item No.	Pcs/ctn
Soft-close	C80C6A3F	200
Sprung	C80C6A3	200



PRODUCT



DESCRIPTION

- Opening angle: 125°
- Available glass door thickness: 3-6mm
- Adhesion distance (K): 0-16,5mm

APPLICATION

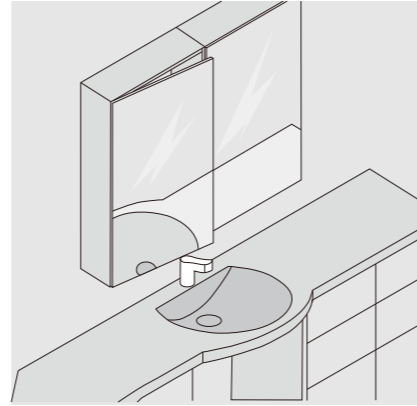

PLANNING

Space needed to open the door

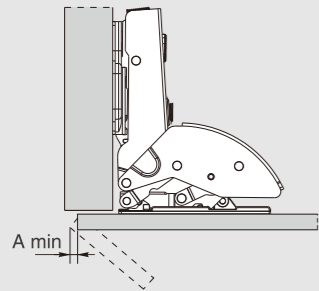

	T=	3	4	5	6								
K=1.5	A=	13.6	14.4	15.2	16.1								
K=3.0	A=	11.2	12.1	12.9	13.8								
K=4.5	A=	8.9	9.8	10.7	11.6								
K=6.0	A=	6.8	7.7	8.6	9.5								
K=7.5	A=	4.2	5.0	5.8	6.6								
K=8.0	A=	2.8	3.8	4.8	5.8								
		-	-	-	-								
K=16.5	A=	0	0	0.3	0.8								

Space needed to open the door

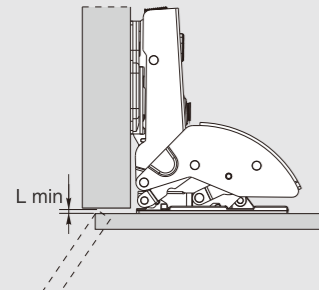

	T=	3	4	5	6								
K=1.5	L=	0	0	0	0								
K=3.0	L=	0	0	0	0								
K=3.5	L=	0	0	0	0								
		-	-	-	-								
K=16.5	L=	0	0	0	0								

- The above values are calculated on the assumption that the doors have square edges.
- They are reduced if the doors have radiused edges.

C=0 Application with full overlay door

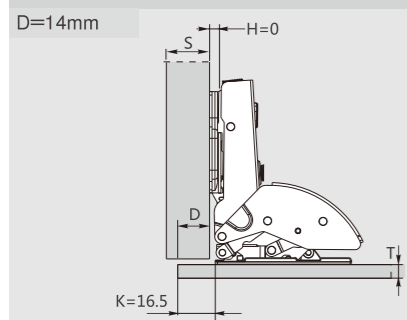

C=7.5 Application with half overlay door

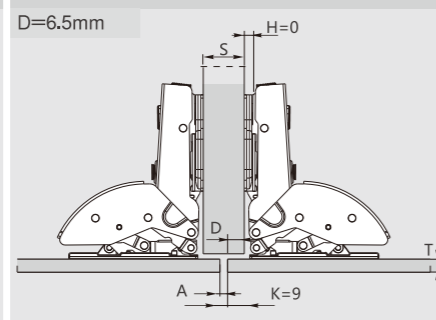

C=15 Application with inset door

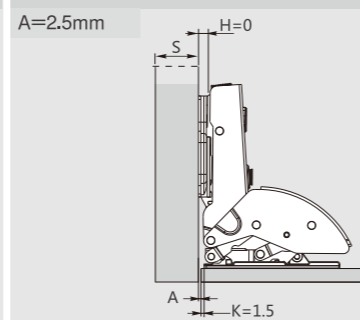

ORDER INFORMATION



Adhesion distance:

Assembly instructions: Please contact your glass or door supplier concerning the right adhesive and its use.

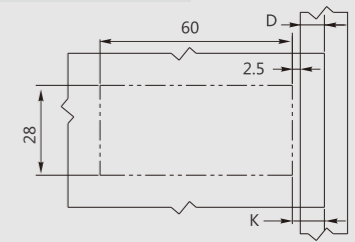

Limitation of liability:

As the adhesive and/or adhesive process are beyond our control, DTC cannot accept liability for claims in this regard.

Use these formulas to determine the type of hinge arm, the adhesion distance "K" and the height of the mounting plate "H" for each door application.

$$K(\min 0, \max 16.5) = D + 2.5$$

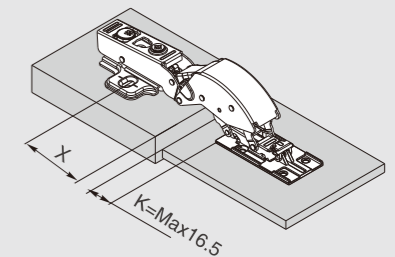

Caution

Drilling distance: Full overlay, Half overlay X=46, Inset X=46+T+1

Nickel plated(A01)

Titanium black(A08)

C80 Series 125° snap-on cam-adjustable soft-close mirror hinges

Full overlay C=0



$$H = -2.5 + K - (D)$$

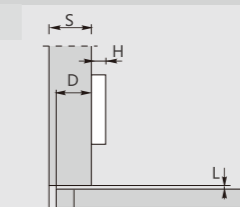

Half overlay C=7.5



$$H = -2.5 + K - (D)$$

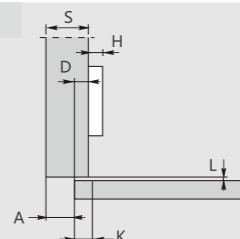

Inset C=15



$$H = -2.5 + K + (A)$$

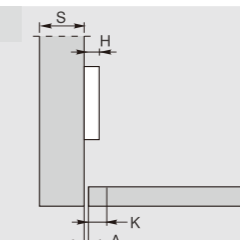

	Item No.	Pcs/ctn
Soft-close	C80A689F	200
Sprung	C80A689	200

	Item No.	Pcs/ctn
Soft-close	C80A689F	200
Sprung	C80A689	200

	Item No.	Pcs/ctn
Soft-close	C80A689F	200
Sprung	C80A689	200



PRODUCT



DESCRIPTION

- Opening angle: 110°
- Depth of hinge cup: 11.5mm
- Diameter of hinge cup: 35mm
- Range of door thickness: 16-26mm
- Possible drilling distances on the door(K): 3-6mm

APPLICATION

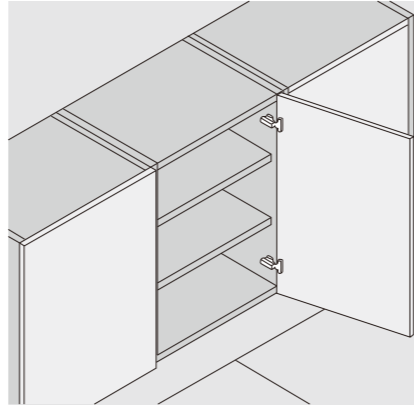

PLANNING

Space needed to open the door

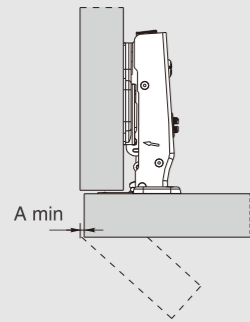

	T=	16	17	18	19	20	21	22	23	24	25	26
K=3	A=	0.7	0.9	1.2	1.5	1.8	2.2	2.6	3.2	3.8	4.5	5.3
K=4	A=	0.7	0.9	1.1	1.4	1.8	2.1	2.5	3.0	3.5	4.4	4.9
K=5	A=	0.6	0.9	1.1	1.4	1.7	2.0	2.4	2.9	3.4	3.9	4.6
K=6	A=	0.6	0.8	1.1	1.3	1.6	2.0	2.4	2.8	3.2	3.8	4.4

Space needed to open the door

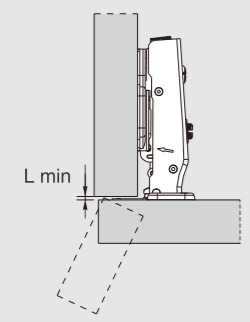

	T=	16	17	18	19	20	21	22	23	24	25	26
K=3	L=	0.0	0.0	0.0	0.0	0.0	0.0	0.0	0.0	0.0	0.0	0.1
K=4	L=	0.0	0.0	0.0	0.0	0.0	0.0	0.2	0.4	0.7	0.9	1.1
K=5	L=	0.0	0.2	0.4	0.6	0.8	1.0	1.2	1.4	1.6	1.8	2.0
K=6	L=	0.9	1.2	1.4	1.6	1.8	2.0	2.2	2.4	2.6	2.8	3.0

- The above values are calculated on the assumption that the doors have square edges.
- They are reduced if the doors have radiused edges.

Projection of the door

Projection of the door from the cabinet side at the max opening. The figures are based on a straight arm hinge, H=0mm mounting plate and drilling distance (K) = 3mm.

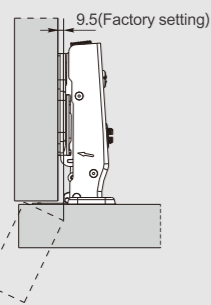

"C" value

$$C = 20 + K + A$$

With this formula you can obtain the max thickness of the moulded door that can be opened without touching adjacent carcass sides, doors or walls, whilst bearing in mind the above L-K-T values.

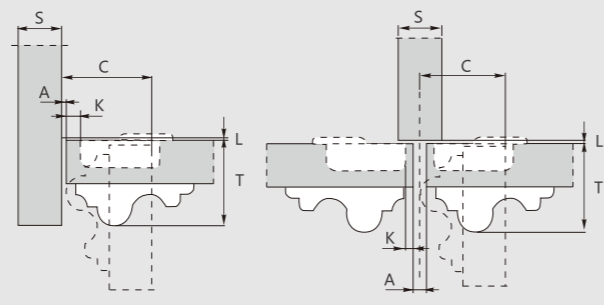

ORDER INFORMATION



Φ 35mm Options of screws and dowels:

M10 dowel Dowel No: M	Expandable dowel Dowel No: K
M8 dowel Dowel No: N	Expandable dowel Dowel No: K0
Euro screw Dowel No: B	Quick dowel Dowel No: T0

Φ 35mm Hinge cup types

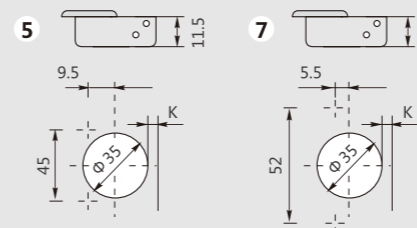

Use these formulas to determine the type of hinge arm, the drilling distance "K" and the height of the mounting plate "H" for each door application.

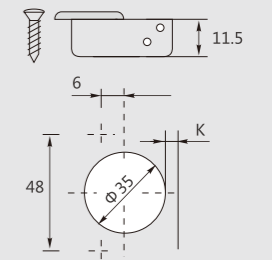

Nickel plated(A01) Titanium black(A08)

C80 Series 110° snap-on soft-close hinges

Full overlay C=0



H=12+K-(D)
(Factory setting)

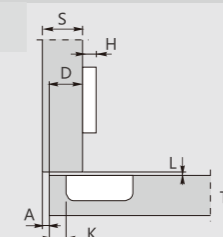

	Item No.	Pcs/ctn
Soft-close	C80A476F	200
Sprung	C80A476	200

Half overlay C=9



H=3+K-(D)
(Factory setting)

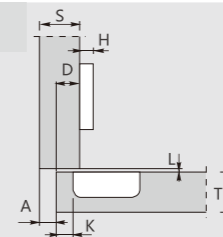

	Item No.	Pcs/ctn
Soft-close	C80B476F	200
Sprung	C80B476	200

Inset C=18



H=6+K+(A)
(Factory setting)

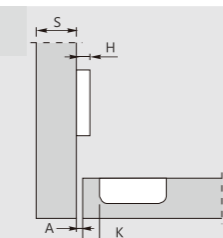

	Item No.	Pcs/ctn
Soft-close	C80C476F	200
Sprung	C80C476	200

PIVOT-PRO

C80 Series 110° Snap-on Soft-close Aluminum Frame Hinges



PRODUCT



DESCRIPTION

- Opening angle: 110°
- Drilling dimension on aluminium frame hinge head: 28mm
- Range of width of aluminium frame (V): 19-22mm

APPLICATION

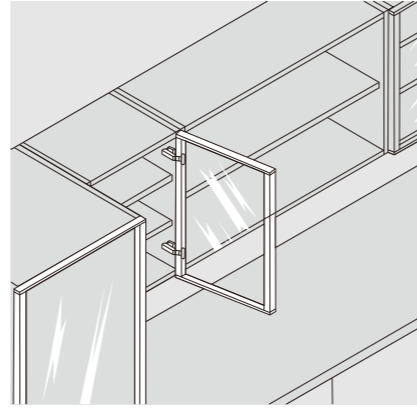

ORDER INFORMATION



PLANNING

Space needed to open the door

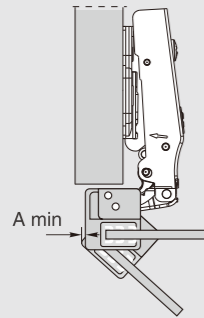

	T=	16	17	18	19	20	21	22	23	24	25	26
V=19	A=	0.7	0.9	1.2	1.5	1.8	2.2	2.6	3.2	3.8	4.5	5.3
V=20	A=	0.7	0.9	1.1	1.4	1.8	2.1	2.5	3.0	3.5	4.4	4.9
V=21	A=	0.6	0.9	1.1	1.4	1.7	2.0	2.4	2.9	3.4	3.9	4.6
V=22	A=	0.6	0.8	1.1	1.3	1.6	2.0	2.4	2.8	3.2	3.8	4.4

Drilling dimensions on aluminium frame

V: 19mm-22mm

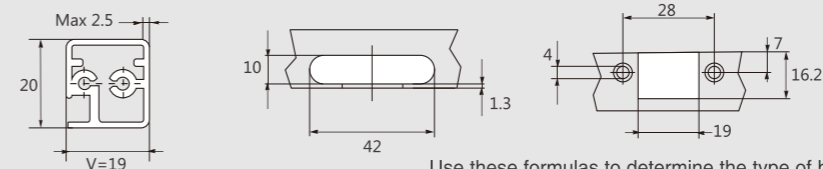

Use these formulas to determine the type of hinge arm, the drilling distance "K" and the height of the mounting plate "H" for each door application.

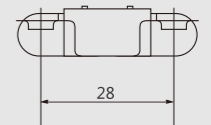

Nickel plated(A01)

Titanium black(A08)

Space needed to open the door

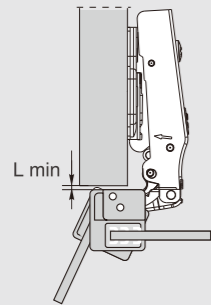

	T=	16	17	18	19	20	21	22	23	24	25	26
V=19	L=	0.0	0.0	0.0	0.0	0.0	0.0	0.0	0.0	0.0	0.0	0.1
V=20	L=	0.0	0.0	0.0	0.0	0.0	0.0	0.2	0.4	0.7	0.9	1.1
V=21	L=	0.0	0.2	0.4	0.6	0.8	1.0	1.2	1.4	1.6	1.8	2.0
V=22	L=	0.9	1.2	1.4	1.6	1.8	2.0	2.2	2.4	2.6	2.8	3.0

- The above values are calculated on the assumption that the doors have square edges.
- They are reduced if the doors have radiused edges.

C80 Series 110° snap-on soft-close aluminum frame hinges

Full overlay C=0



H=-2+V-(D)

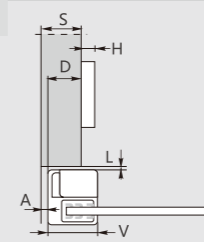

	Item No.	Pcs/ctn
Soft-close	C80A478F	200
Sprung	C80A478	200

Half overlay C=9



H=-11+V-(D)

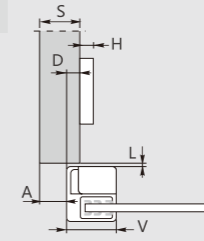

	Item No.	Pcs/ctn
Soft-close	C80B478F	200
Sprung	C80B478	200

Inset C=18



H=-20.5+V+(A)

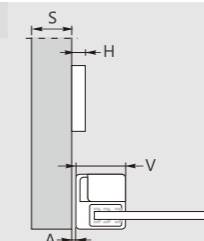

	Item No.	Pcs/ctn
Soft-close	C80C478F	200
Sprung	C80C478	200

C=0 Application with full overlay door

D=18mm

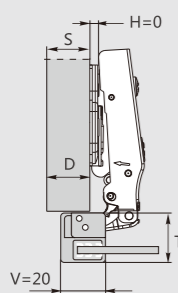

C=9 Application with half overlay door

D=9mm

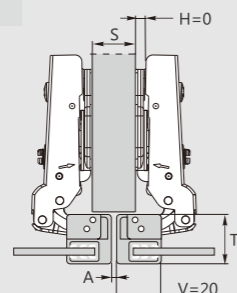

C=18 Application with inset door

A=0.5mm

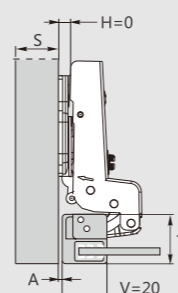

PRODUCT



DESCRIPTION

- Opening angle: 55°
- Depth of hinge cup: 11.5mm
- Diameter of hinge cup: 35mm
- Range of door thickness: 14-26mm
- Possible drilling distances on the door(K): 3-7 mm

APPLICATION

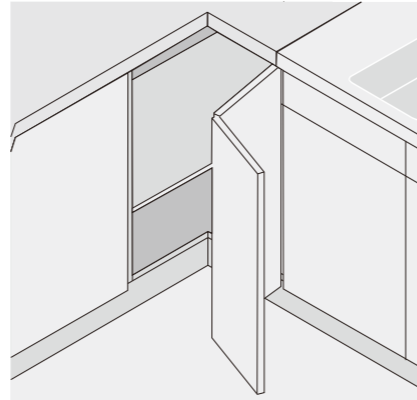

ORDER INFORMATION



Options of screws and dowels:

M10 dowel Dowel No: M	Expandable dowel Dowel No: K
M8 dowel Dowel No: N	Expandable dowel Dowel No: K0
Euro screw Dowel No: B	Quick dowel Dowel No: T0

Φ 35MM CORNER DOOR, BI-FOLD DOOR, -45°~45° ANGLED HINGE APPLICATIONS

Kitchen corner door applications

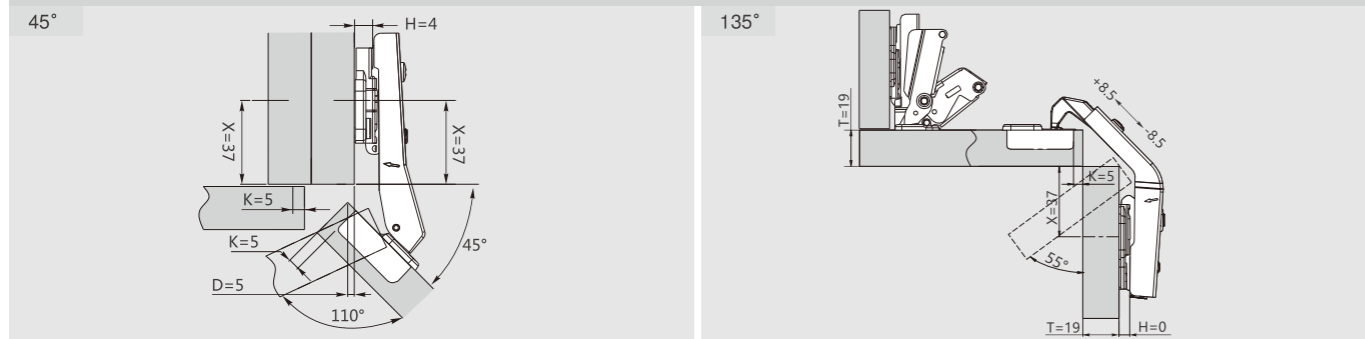

Negative angled hinge applications

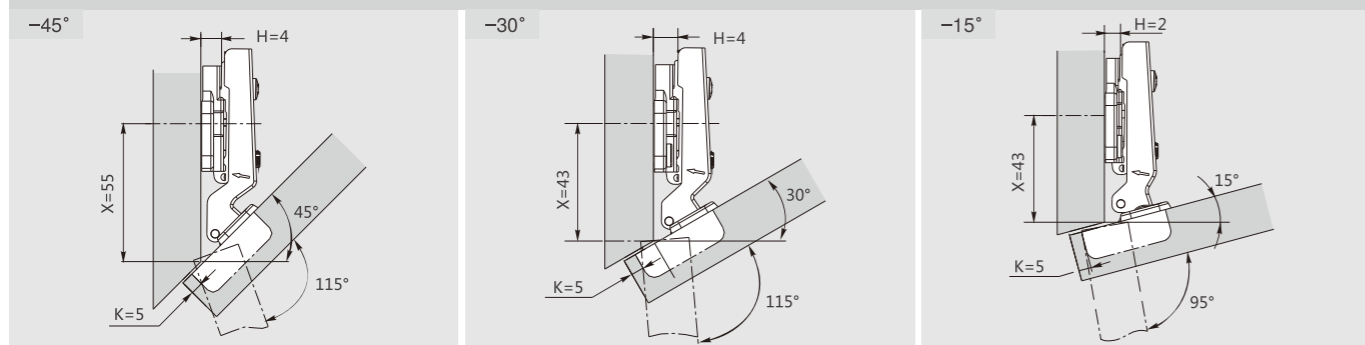

Positive angled hinge applications

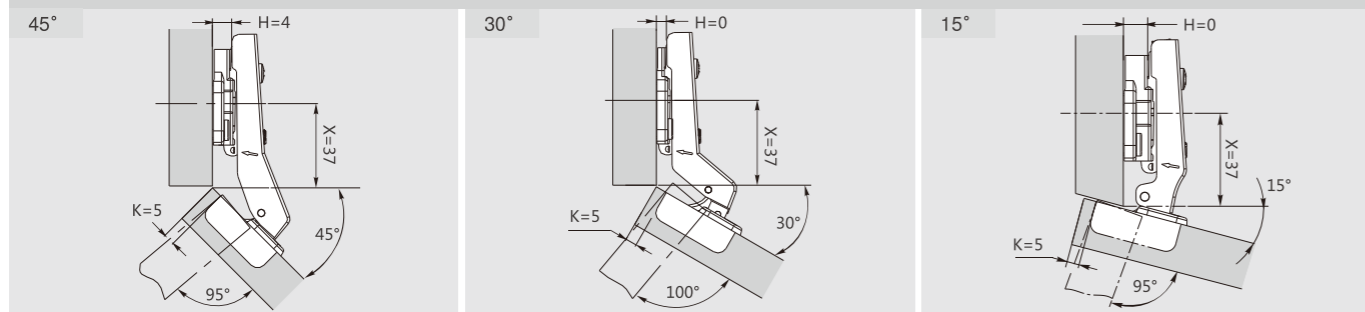

Nickel plated(A01) Titanium black(A08)

C80 Series snap-on 135° angled hinges

T=Door thickness D=Required door overlay H=Height of the mounting plate
X=Distance from bottom plate screw hole to plate edge K=Drilling distance
L=Gap between door and carcass

Door thickness	Mounting plate height
14 ≤ T < 19	H=2
T=19	H=2
19 < T ≤ 26	H=0

Item No.	Pcs/ctn
Spring C80H476	200



PRODUCT



DESCRIPTION

- Opening angle: 110°
- Depth of hinge cup: 11.5mm
- Diameter of hinge cup: 35mm
- Range of door thickness: 16-26mm
- Possible drilling distances on the door(K): 3-6mm

APPLICATION

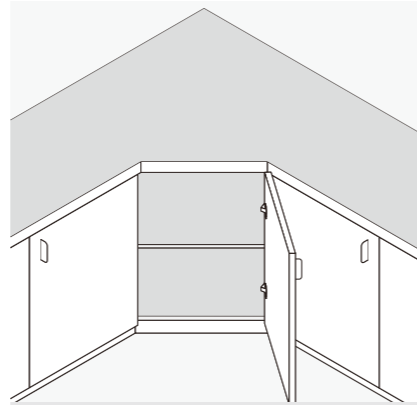

ORDER INFORMATION

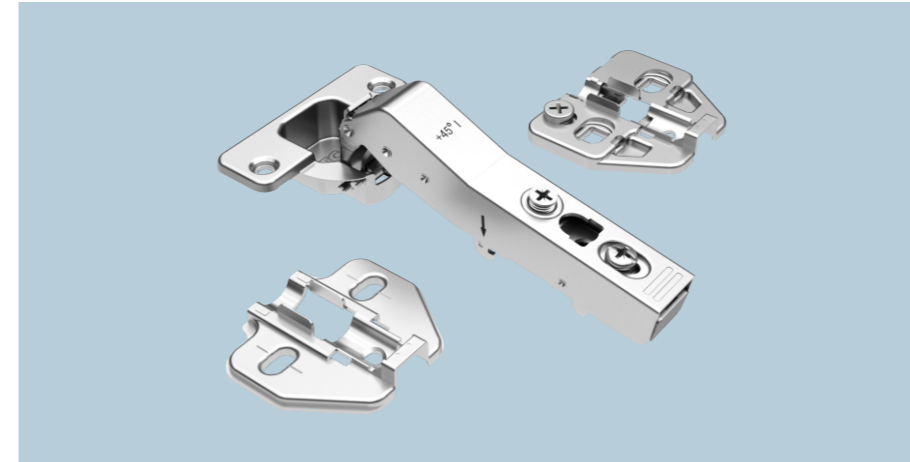

Φ 35mm Options of screws and dowels:

M10 dowel Dowel No: M	Expandable dowel Dowel No: K
M8 dowel Dowel No: N	Expandable dowel Dowel No: K0
Euro screw Dowel No: B	Quick dowel Dowel No: T0

PLANNING

Space needed to open the door

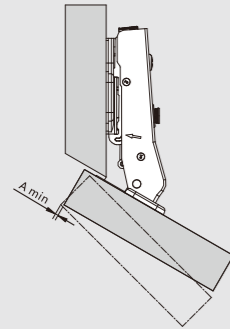

	T=	14	15	16	17	18	19	20	21	22	23	24
K=3	A=	0.3	0.5	0.7	0.9	1.2	1.5	1.8	2.2	2.6	3.1	3.8
K=3	A=	0.3	0.5	0.7	0.9	1.1	1.4	1.7	2.1	2.5	3.0	3.5
K=3	A=	0.3	0.5	0.7	0.9	1.1	1.4	1.7	2.0	2.4	2.9	3.4
K=3	A=	0.3	0.5	0.6	0.8	1.1	1.3	1.6	2.0	2.3	2.8	3.2
K=3	A=	0.3	0.4	0.6	0.8	1.0	1.3	1.6	1.9	2.3	2.7	3.1
K=3	A=	0.3	0.4	0.6	0.8	1.0	1.3	1.5	1.9	2.2	2.6	3.0

- T=Door thickness
- K=Cup hole drilling distance from door edge

Space needed to open the door

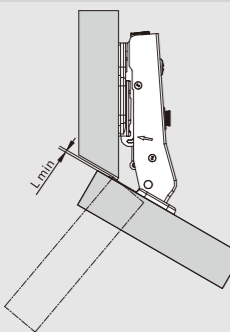

	T=	14	15	16	17	18	19	20	21	22	23	24
K=3	L=	0.0	0.0	0.0	0.0	0.0	0.0	0.0	0.0	0.0	0.0	0.0
K=3	L=	0.0	0.0	0.0	0.0	0.0	0.0	0.0	0.0	0.0	0.0	0.1
K=3	L=	0.0	0.0	0.0	0.0	0.1	0.3	0.4	0.6	0.8	1.0	1.1
K=3	L=	0.4	0.6	0.7	0.9	1.1	1.2	1.4	1.6	1.8	1.9	2.1
K=3	L=	1.4	1.5	1.7	1.9	2.1	2.2	2.4	2.6	2.8	2.9	3.1
K=3	L=	2.4	2.5	2.7	2.9	3.0	3.2	3.4	3.6	3.7	3.9	4.1

- The above values are calculated on the assumption that the doors have square edges.
- They are reduced if the doors have radiused edges.

Φ 35mm Hinge cup types

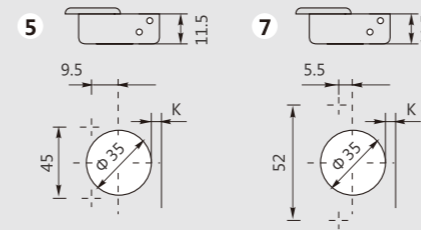

The solution of assembly problems where doors are mounted at a positive or negative angle requires the verification of drilling distances by a practical trial. Please do not hesitate to consult our technical support department for assistance.

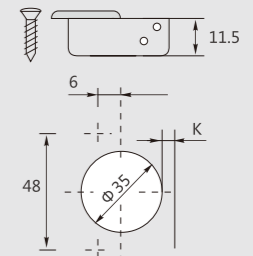

Nickel plated(A01) Titanium black(A08)

C80 Series snap-on soft-close 30° angled hinges

Overlay 30°

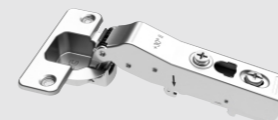

C80 series snap-on soft-close 45° angled hinges

Small Overlay 45°

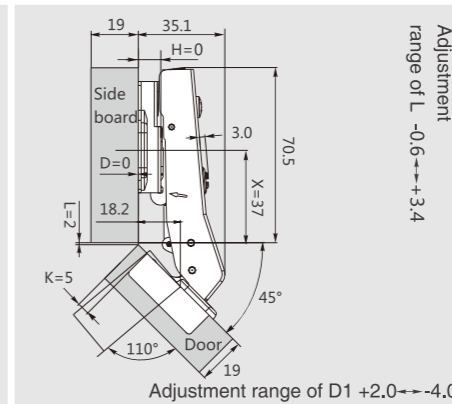
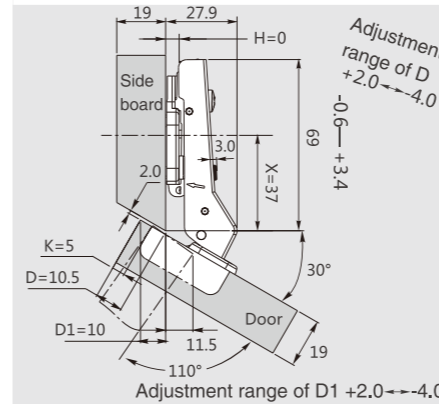

	Item No.	Pcs/ctn
Soft-close	C80W476F	200
Sprung	C80W476	200

	Item No.	Pcs/ctn
Soft-close	C80E476F	200
Sprung	C80E476	200



PRODUCT



DESCRIPTION

- Opening angle: 110°
- Depth of hinge cup: 11.5mm
- Diameter of hinge cup: 35mm
- Range of door thickness: 16-26mm
- Possible drilling distances on the door(K): 3-6mm

APPLICATION

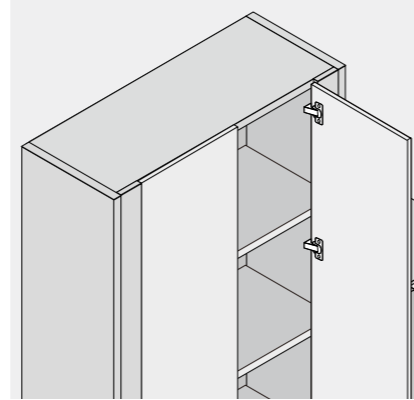

PLANNING

Space needed to open the door

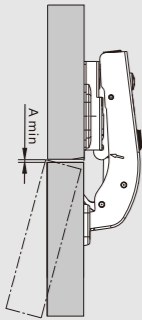

	T=	14	15	16	17	18	19	20	21	22	23	24
K=3	A=	0.3	0.5	0.7	0.9	1.2	1.5	1.8	2.2	2.6	3.1	3.8
K=3	A=	0.3	0.5	0.7	0.9	1.1	1.4	1.7	2.1	2.5	3.0	3.5
K=3	A=	0.3	0.5	0.7	0.9	1.1	1.4	1.7	2.0	2.4	2.9	3.4
K=3	A=	0.3	0.5	0.6	0.8	1.1	1.3	1.6	2.0	2.3	2.8	3.2
K=3	A=	0.3	0.4	0.6	0.8	1.0	1.3	1.6	1.9	2.3	2.7	3.1
K=3	A=	0.3	0.4	0.6	0.8	1.0	1.3	1.5	1.9	2.2	2.6	3.0

- T=Door thickness
- K=Cup hole drilling distance from door edge

Space needed to open the door

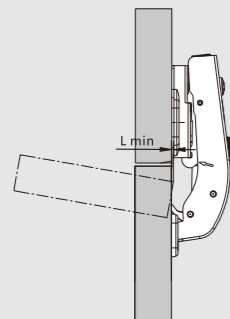

	T=	14	15	16	17	18	19	20	21	22	23	24
K=3	L=	0.0	0.0	0.0	0.0	0.0	0.0	0.0	0.0	0.0	0.0	0.0
K=3	L=	0.0	0.0	0.0	0.0	0.0	0.0	0.0	0.0	0.0	0.0	0.1
K=3	L=	0.0	0.0	0.0	0.0	0.1	0.3	0.4	0.6	0.8	1.0	1.1
K=3	L=	0.4	0.6	0.7	0.9	1.1	1.2	1.4	1.6	1.8	1.9	2.1
K=3	L=	1.4	1.5	1.7	1.9	2.1	2.2	2.4	2.6	2.8	2.9	3.1
K=3	L=	2.4	2.5	2.7	2.9	3.0	3.2	3.4	3.6	3.7	3.9	4.1

- The above values are calculated on the assumption that the doors have square edges.
- They are reduced if the doors have radiused edges.

ORDER INFORMATION

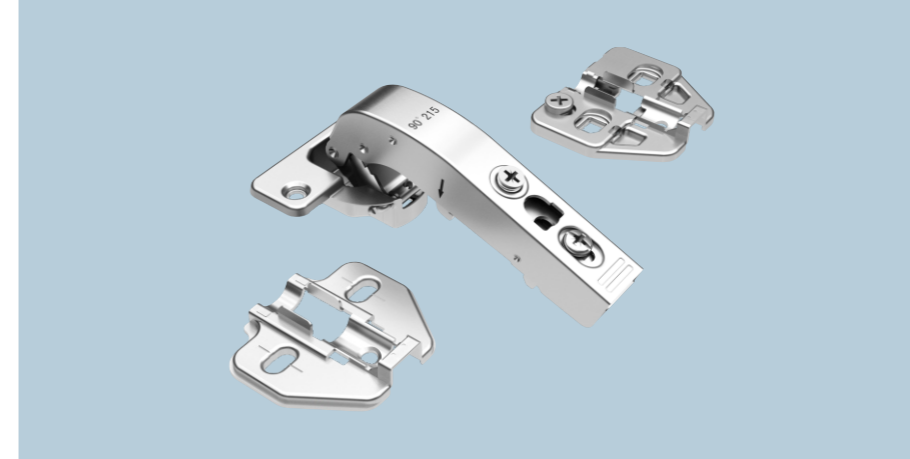

Φ 35mm Options of screws and dowels:

M10 dowel Dowel No: M	Expandable dowel Dowel No: K
M8 dowel Dowel No: N	Expandable dowel Dowel No: K0
Euro screw Dowel No: B	Quick dowel Dowel No: T0

Φ 35mm Hinge cup types

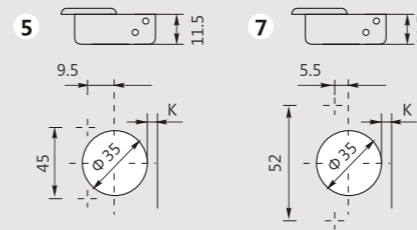

The solution of assembly problems where doors are mounted at a positive or negative angle requires the verification of drilling distances by a practical trial. Please do not hesitate to consult our technical support department for assistance.

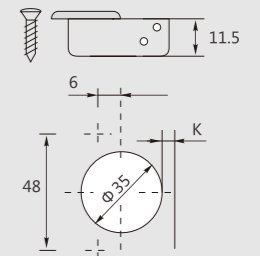

Nickel plated(A01) Titanium black(A08)

C80 Series snap-on soft-close 90° angled hinges

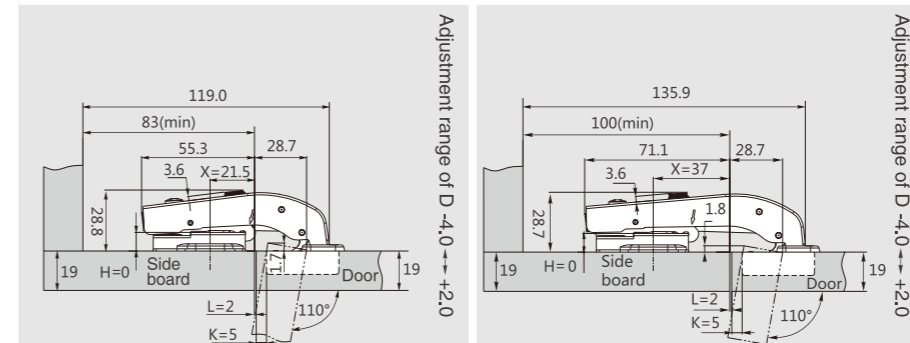

Adjustment range of L -0.6 --- +3.4

Adjustment range of L -0.6 --- +3.4

	Item No.	Pcs/ctn		Item No.	Pcs/ctn
Soft-close	C80J476F	200	Soft-close	C80G476F	200
Sprung	C80J476	200	Sprung	C80G476	200

PIVOT-PRO

C80 Series 155° Snap-on Soft-close Hinges



PRODUCT



DESCRIPTION

- Opening angle: 155°
- Depth of hinge cup: 11.5mm
- Diameter of hinge cup: 35mm
- Range of door thickness: 16-24mm
- Possible drilling distances on the door(K): 3-6mm

APPLICATION

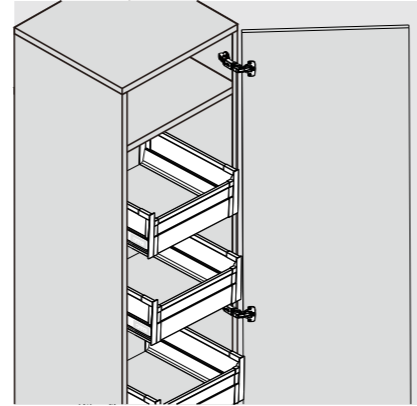

PLANNING

Space needed to open the door

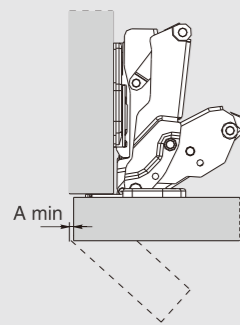

	T=	16	17	18	19	20	21	22	23	24		
K=3	A=	0	0	0	0	0	0	0	0	0		
K=4	A=	0	0	0	0	0	0	0	0	0		
K=5	A=	0	0	0	0	0	0	0	0	0		
K=6	A=	0	0	0	0	0	0	0	0	0		

Application

The door combined with a mounting plate H=0, opens at 90° with a 2.3mm protrusion allowing objects (e.g. drawers) move from inside of the cabinet.

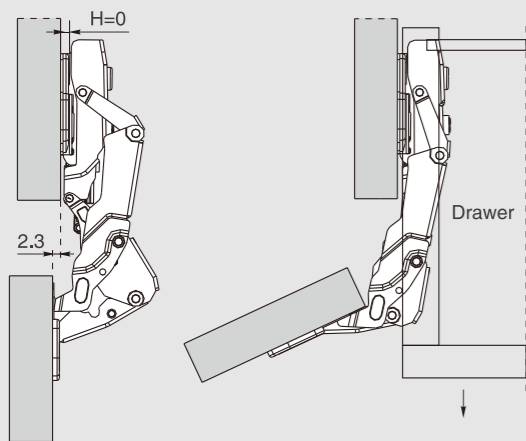

Full overlay C=0

No gap is required when door thickness is less than 24mm. A trial assembly is recommended when door thickness is more than 24mm.

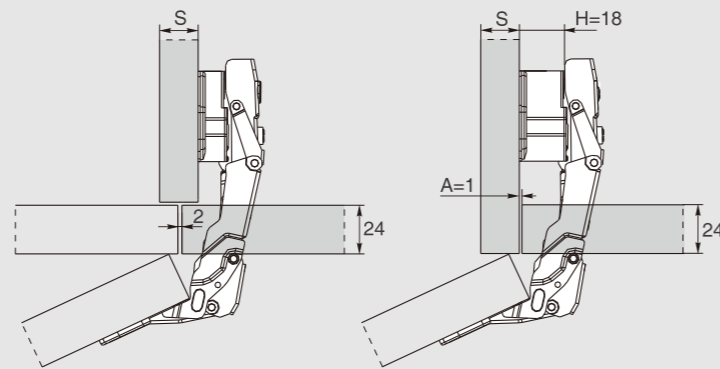

Half overlay C=9

Inset C=18

ORDER INFORMATION

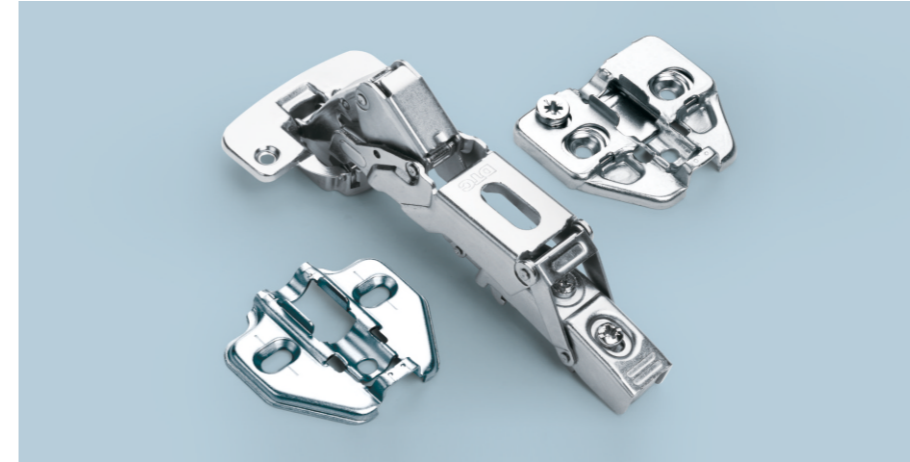

Φ 35mm Options of screws and dowels:

M10 dowel Dowel No: M	Expandable dowel Dowel No: K0
M8 dowel Dowel No: N	Quick dowel Dowel No: T0
Expandable dowel Dowel No: K	

Φ 35mm Hinge cup types

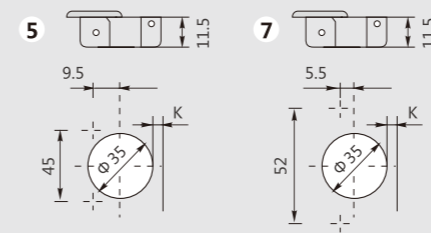

Use these formulas to determine the type of hinge arm, the drilling distance "K" and the height of the mounting plate "H" for each door application.

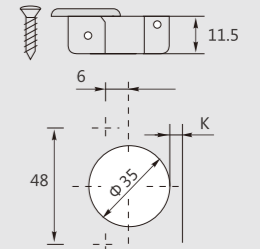

Nickel plated(A01) Titanium black(A08)

C80 Series 155° snap-on soft-close hinges

Full overlay C=0



Small overlay C=4



Half overlay C=9

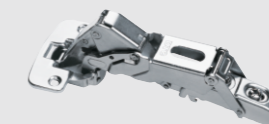

Inset C=18

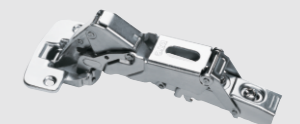

H=11+K-(D)

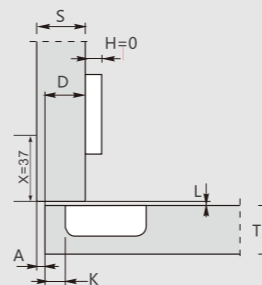

K=5, for full overlay D=16±2mm, H=0 mounting plate only

	Item No.	Pcs/ctn
Soft-close	C80A506F	100
Sprung	C80A506	100

H=11+K-(D)

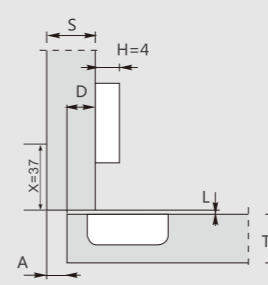

K=5, for small overlay D=12±2mm, H=4 mounting plate only

	Item No.	Pcs/ctn
Soft-close	C80A506F	100
Sprung	C80A506	100

H=11+K-(D)

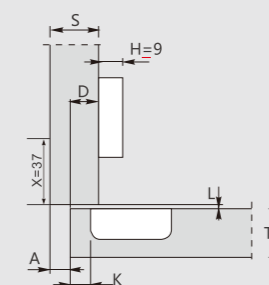

K=5, for half overlay D=7±2mm, H=9 mounting plate only

	Item No.	Pcs/ctn
Soft-close	C80A506F	100
Sprung	C80A506	100

H=11+K+(A)

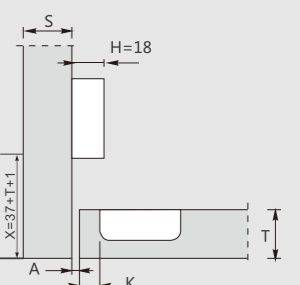

K=5, for inset door, H=18 mounting plate only

	Item No.	Pcs/ctn
Soft-close	C80A506F	100
Sprung	C80A506	100



PRODUCT



DESCRIPTION

- Opening angle: 95°
- Depth of hinge cup: 11.5mm
- Diameter of hinge cup: 35mm
- Range of door thickness: 19-35mm
- Possible drilling distances on the door(K): 3-9mm

APPLICATION

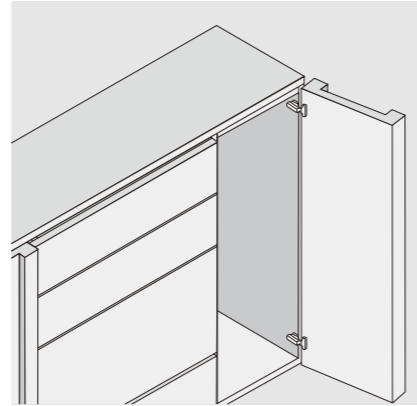

PLANNING

Space needed to open the door

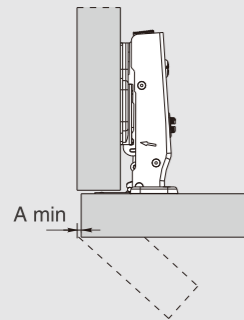

T=	19	20	21	22	23	24	25	26	27	28	29	30	31	32 - 35
K=3 A=	0.1	0.2	0.3	0.4	0.5	0.7	0.9	1.3	2.2	3.2	4.1	5.0	6.0	7.0 - 10
K=4 A=	0.1	0.2	0.3	0.4	0.5	0.7	0.8	1.0	1.6	2.5	3.5	4.4	5.3	6.3 - 9.1
K=5 A=	0.1	0.2	0.3	0.4	0.5	0.7	0.8	1.0	1.2	2.0	2.9	3.7	4.7	5.6 - 8.4
K=6 A=	0.1	0.2	0.3	0.4	0.5	0.6	0.8	1.0	1.2	1.4	2.3	3.2	4.1	5.0 - 7.8
K=7 A=	0.1	0.2	0.3	0.4	0.5	0.6	0.8	1.0	1.2	1.4	1.8	2.7	3.6	4.4 - 7.0
K=8 A=	0.1	0.2	0.3	0.4	0.5	0.6	0.8	1.0	1.1	1.4	1.6	2.2	3.1	3.9 - 6.5
K=9 A=	0.1	0.2	0.3	0.4	0.5	0.6	0.8	0.9	1.1	1.3	1.6	1.8	2.6	3.4 - 6.0

Space needed to open the door

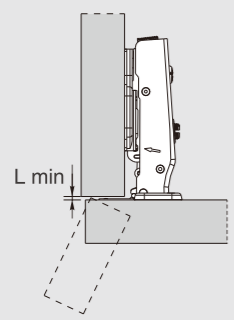

T=	19	20	21	22	23	24	25	26	27	28	29	30	31	32 - 35
K=3 L=	0.0	0.0	0.0	0.0	0.0	0.0	0.0	0.0	0.0	0.0	0.0	0.0	0.0	0.0 - 0.0
K=4 L=	0.0	0.0	0.0	0.0	0.0	0.0	0.0	0.0	0.0	0.0	0.0	0.0	0.0	0.0 - 0.0
K=5 L=	0.0	0.0	0.0	0.0	0.0	0.0	0.0	0.0	0.0	0.2	0.2	0.3	0.4	0.5 - 0.7
K=6 L=	0.3	0.4	0.5	0.6	0.7	0.7	0.8	0.9	1.0	1.2	1.2	1.3	1.4	1.5 - 1.7
K=7 L=	1.3	1.4	1.5	1.6	1.7	1.7	1.8	1.9	2.0	2.2	2.2	2.3	2.4	2.5 - 2.7
K=8 L=	2.3	2.4	2.5	2.6	2.7	2.7	2.8	2.9	3.0	3.2	3.2	3.3	3.4	3.5 - 3.7
K=9 L=	3.3	3.4	3.5	3.6	3.7	3.7	3.8	3.9	4.0	4.2	4.2	4.3	4.4	4.5 - 4.7

- The above values are calculated on the assumption that the doors have square edges.
- They are reduced if the doors have radiused edges.

Projection of the door

Projection of the door from the cabinet side at the max opening. The figures are based on a straight arm hinge, H=0mm mounting plate and drilling distance (K) =3mm.

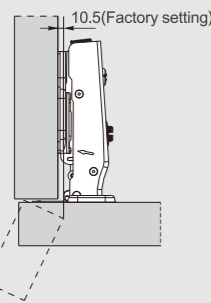

"C" value

$$C=22+K+A$$

With this formula you can obtain the max thickness of the moulded door that can be opened without touching adjacent carcass sides, doors or walls, whilst bearing in mind the above L-K-T values.

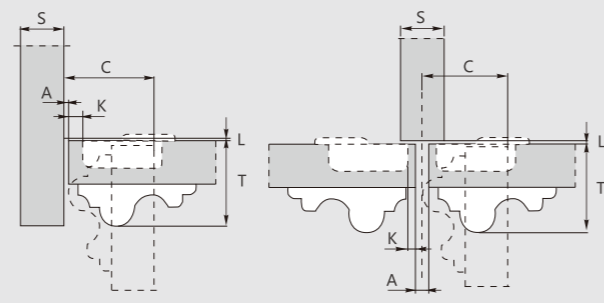

ORDER INFORMATION



Φ 35mm Options of screws and dowels:

M10 dowel Dowel No: M	Expandable dowel Dowel No: K
M8 dowel Dowel No: N	Expandable dowel Dowel No: K0
Euro screw Dowel No: B	Quick dowel Dowel No: T0

Φ 35mm Hinge cup types

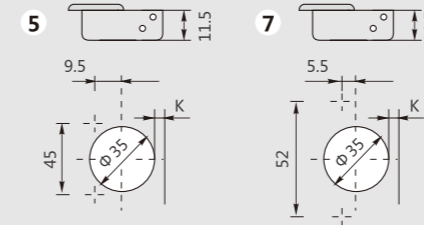

Use these formulas to determine the type of hinge arm, the drilling distance "K" and the height of the mounting plate "H" for each door application.

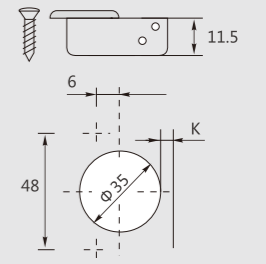

Nickel plated(A01) Titanium black(A08)

C80 Series 95° snap-on soft-close hinges for thick door

Full overlay C=0



H=12+K-(D)
(Factory setting)

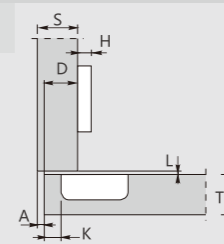

Half overlay C=9



H=3+K-(D)
(Factory setting)

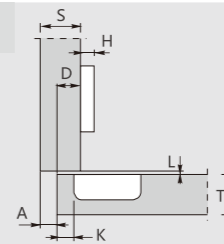

Inset C=18



H=-6+K+(A)
(Factory setting)

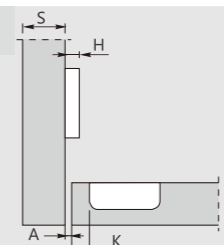

	Item No.	Pcs/ctn
Soft-close	C80A416F	200
Sprung	C80A416	200

	Item No.	Pcs/ctn
Soft-close	C80B416F	200
Sprung	C80B416	200

	Item No.	Pcs/ctn
Soft-close	C80C416F	200
Sprung	C80C416	200



PRODUCT



DESCRIPTION

- Opening angle: 110°
- Depth of hinge cup: 11.5mm
- Diameter of hinge cup: 35mm
- Range of door thickness: 16-26mm
- Possible drilling distances on the door(K): 3-6 mm

APPLICATION

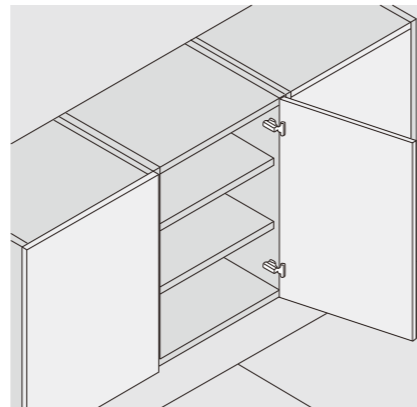

PLANNING

Space needed to open the door

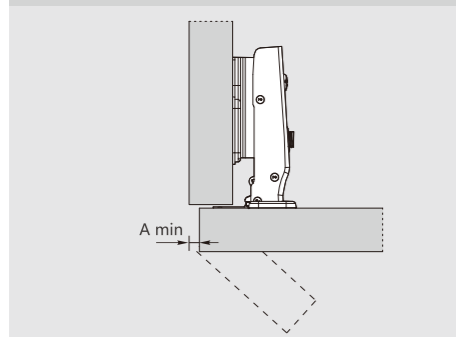

	T=	16	17	18	19	20	21	22	23	24	25	26
K=3	A=	0.7	0.9	1.2	1.5	1.8	2.2	2.6	3.2	3.8	4.5	5.3
K=4	A=	0.7	0.9	1.1	1.4	1.8	2.1	2.5	3.0	3.5	4.4	4.9
K=5	A=	0.6	0.9	1.1	1.4	1.7	2.0	2.4	2.9	3.4	3.9	4.6
K=6	A=	0.6	0.8	1.1	1.3	1.6	2.0	2.4	2.8	3.2	3.8	4.4

Space needed to open the door

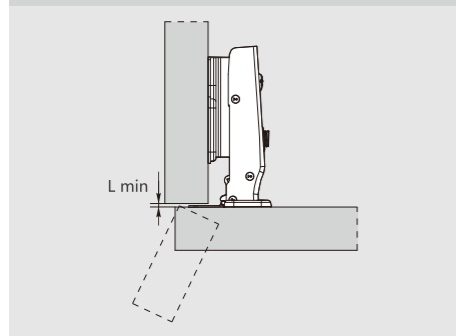

	T=	16	17	18	19	20	21	22	23	24	25	26
K=3	L=	0.0	0.0	0.0	0.0	0.0	0.0	0.0	0.0	0.0	0.0	0.1
K=4	L=	0.0	0.0	0.0	0.0	0.0	0.0	0.2	0.4	0.7	0.9	1.1
K=5	L=	0.0	0.2	0.4	0.6	0.8	1.0	1.2	1.4	1.6	1.8	2.0
K=6	L=	0.9	1.2	1.4	1.6	1.8	2.0	2.2	2.4	2.6	2.8	3.0

- The above values are calculated on the assumption that the doors have square edges.
- They are reduced if the doors have radiused edges.

Projection of the door

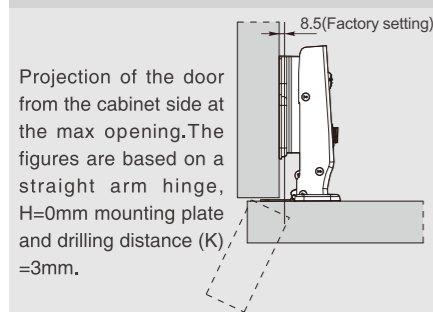

"C" value

$$C = 20 + K + A$$

With this formula you can obtain the max thickness of the moulded door that can be opened without touching adjacent carcass sides, doors or walls, whilst bearing in mind the above L-K-T values.

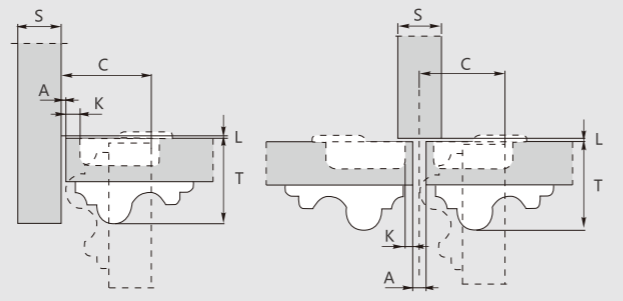

ORDER INFORMATION

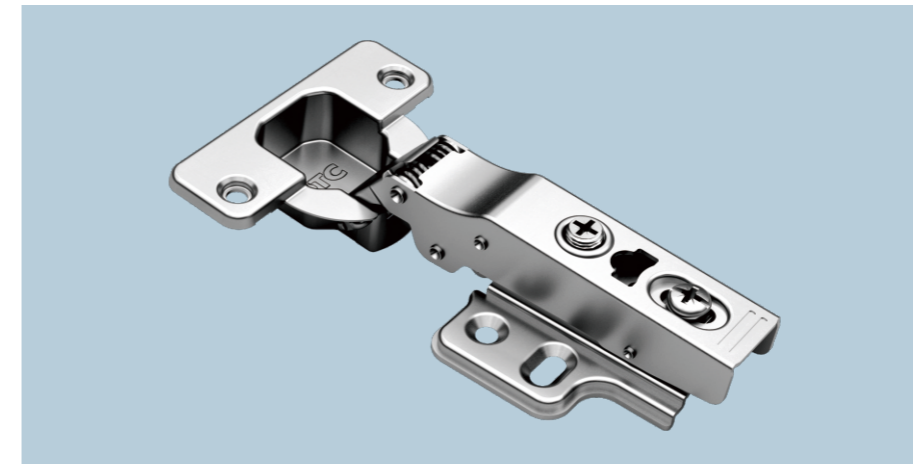

Φ 35mm Options of screws and dowels:

M10 dowel Dowel No: M	Expandable dowel Dowel No: K
M8 dowel Dowel No: N	Expandable dowel Dowel No: K0
Euro screw Dowel No: B	Quick dowel Dowel No: T0

Φ 35mm Hinge cup types

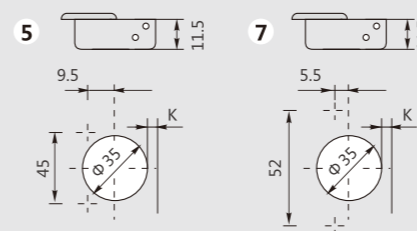

Use these formulas to determine the type of hinge arm, the drilling distance "K" and the height of the mounting plate "H" for each door application.

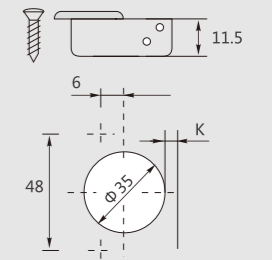

Nickel plated(A01) Titanium black(A08)

B80 series 110° soft-close hinges with integrated plate

Full overlay C=0



$$H = 13 + K - (D)$$

(Factory setting)

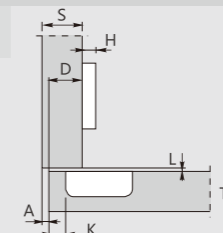

	Item No.	Pcs/ctn
Soft-close	B80A2764H	200
Sprung	B80A2764	200

Half overlay C=9



$$H = 4 + K - (D)$$

(Factory setting)

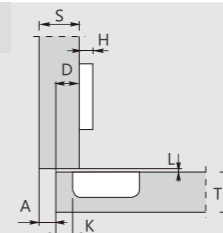

	Item No.	Pcs/ctn
Soft-close	B80B2764H	200
Sprung	B80B2764	200

Inset C=18

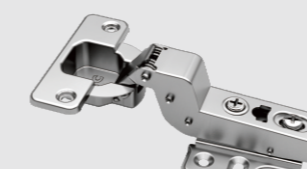

$$H = -6 + K + (A)$$

(Factory setting)

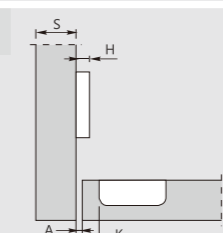

	Item No.	Pcs/ctn
Soft-close	B80C2764H	200
Sprung	B80C2764	200

PIVOT-PRO

B80 Series 95° Soft-close Hinges with Integrated Plate for Thick Door



PRODUCT



DESCRIPTION

- Opening angle: 95°
- Depth of hinge cup: 11.5mm
- Diameter of hinge cup: 35mm
- Range of door thickness: 19-35mm
- Possible drilling distances on the door (K): 3-9 mm

APPLICATION

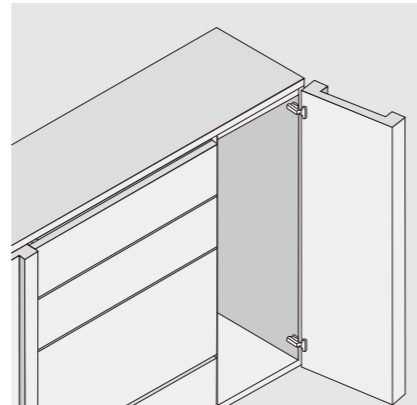

PLANNING

Space needed to open the door

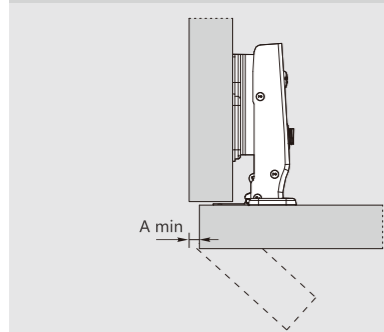

T=	19	20	21	22	23	24	25	26	27	28	29	30	31	32 - 35
K=3 A=	0.1	0.2	0.3	0.4	0.5	0.7	0.9	1.3	2.2	3.2	4.1	5.0	6.0	7.0 - 10
K=4 A=	0.1	0.2	0.3	0.4	0.5	0.7	0.8	1.0	1.6	2.5	3.5	4.4	5.3	6.3 - 9.1
K=5 A=	0.1	0.2	0.3	0.4	0.5	0.7	0.8	1.0	1.2	2.0	2.9	3.7	4.7	5.6 - 8.4
K=6 A=	0.1	0.2	0.3	0.4	0.5	0.6	0.8	1.0	1.2	1.4	2.3	3.2	4.1	5.0 - 7.8
K=7 A=	0.1	0.2	0.3	0.4	0.5	0.6	0.8	1.0	1.2	1.4	1.8	2.7	3.6	4.4 - 7.0
K=8 A=	0.1	0.2	0.3	0.4	0.5	0.6	0.8	1.0	1.1	1.4	1.6	2.2	3.1	3.9 - 6.5
K=9 A=	0.1	0.2	0.3	0.4	0.5	0.6	0.8	0.9	1.1	1.3	1.6	1.8	2.6	3.4 - 6.0

Space needed to open the door

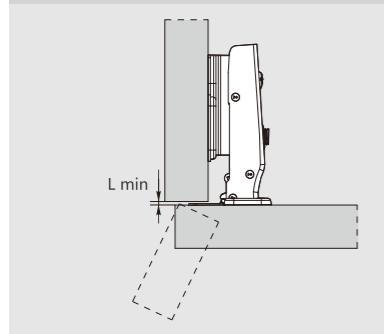

T=	19	20	21	22	23	24	25	26	27	28	29	30	31	32 - 35
K=3 L=	0.0	0.0	0.0	0.0	0.0	0.0	0.0	0.0	0.0	0.0	0.0	0.0	0.0	0.0 - 0.0
K=4 L=	0.0	0.0	0.0	0.0	0.0	0.0	0.0	0.0	0.0	0.0	0.0	0.0	0.0	0.0 - 0.0
K=5 L=	0.0	0.0	0.0	0.0	0.0	0.0	0.0	0.0	0.0	0.2	0.2	0.3	0.4	0.5 - 0.7
K=6 L=	0.3	0.4	0.5	0.6	0.7	0.7	0.8	0.9	1.0	1.2	1.2	1.3	1.4	1.5 - 1.7
K=7 L=	1.3	1.4	1.5	1.6	1.7	1.7	1.8	1.9	2.0	2.2	2.2	2.3	2.4	2.5 - 2.7
K=8 L=	2.3	2.4	2.5	2.6	2.7	2.7	2.8	2.9	3.0	3.2	3.2	3.3	3.4	3.5 - 3.7
K=9 L=	3.3	3.4	3.5	3.6	3.7	3.7	3.8	3.9	4.0	4.2	4.2	4.3	4.4	4.5 - 4.7

- The above values are calculated on the assumption that the doors have square edges.
- They are reduced if the doors have radiused edges.

Projection of the door

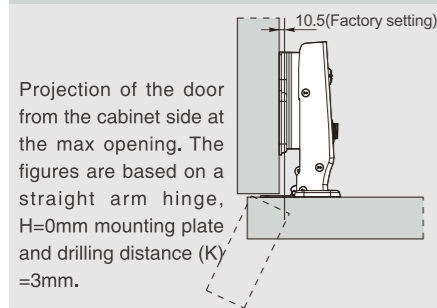

"C" value

$$C = 22 + K + A$$

With this formula you can obtain the max thickness of the moulded door that can be opened without touching adjacent carcass sides, doors or walls, whilst bearing in mind the above L-K-T values.

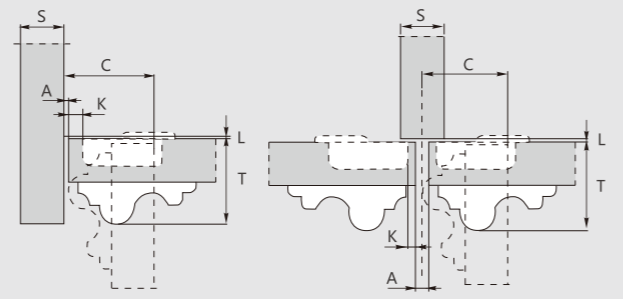

ORDER INFORMATION

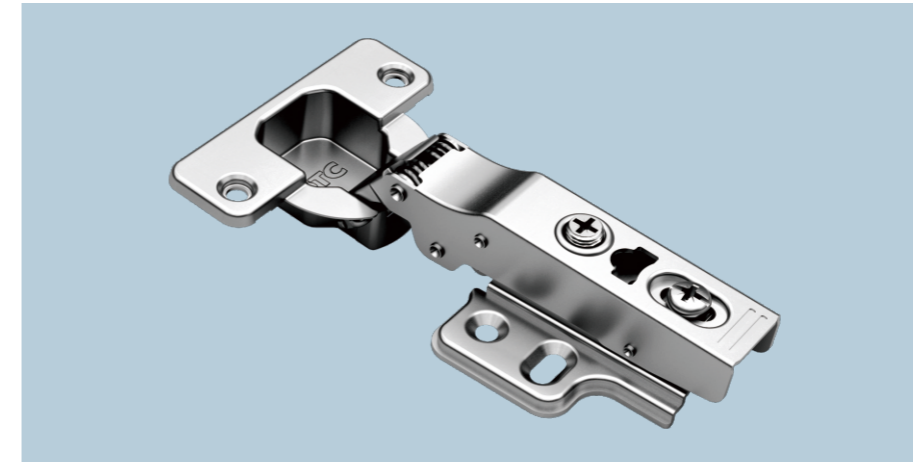

Φ 35mm Options of screws and dowels:

M10 dowel Dowel No: M	Expandable dowel Dowel No: K
M8 dowel Dowel No: N	Expandable dowel Dowel No: K0
Euro screw Dowel No: B	Quick dowel Dowel No: T0

Φ 35mm Hinge cup types

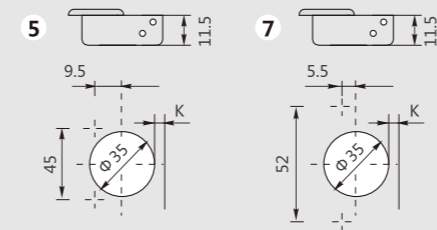

Use these formulas to determine the type of hinge arm, the drilling distance "K" and the height of the mounting plate "H" for each door application.

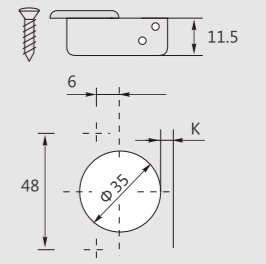

Nickel plated(A01) Titanium black(A08)

B80 series 95° soft-close hinges with integrated plate for thick door

Full overlay C=0



$$H = 12 + K - (D)$$

(Factory setting)

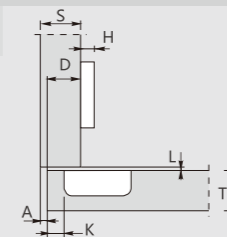

	Item No.	Pcs/ctn
Soft-close	B80A2164H	200
Sprung	B80A2164	200

Half overlay C=9



$$H = 3 + K - (D)$$

(Factory setting)

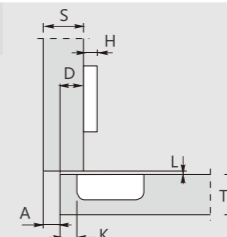

	Item No.	Pcs/ctn
Soft-close	B80B2164H	200
Sprung	B80B2164	200

Inset C=18

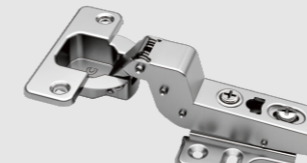

$$H = -6 + K + (A)$$

(Factory setting)

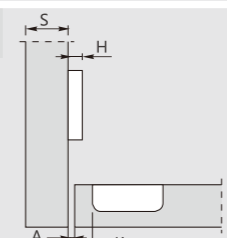

	Item No.	Pcs/ctn
Soft-close	B80C2164H	200
Sprung	B80C2164	200

ORDER INFORMATION

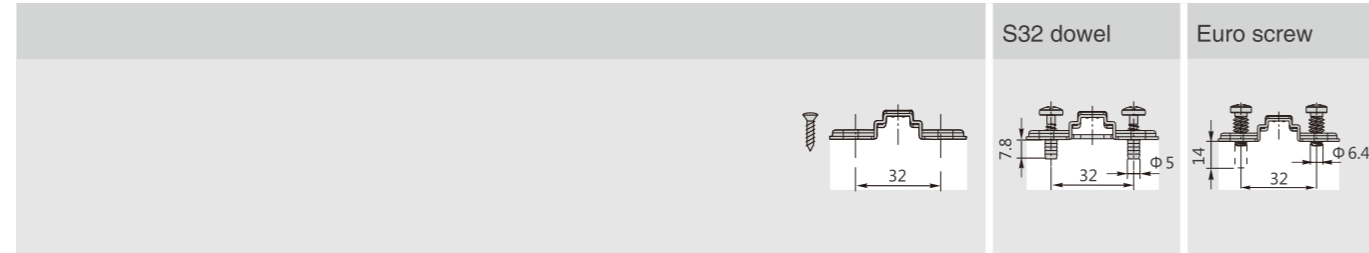

Two-hole mounting plate

Pcs/ctn	Color	Height of mounting plate	Item No.		
			Item No.	Item No.	Item No.
200	Nickel plated(A01) Titanium black(A08)	H=0	89H00AQ	89H01AQ	89H02AQ
		H=2	89H20AQ	89H21AQ	89H22AQ
		H=4	89H40AQ	89H41AQ	89H42AQ
		H=9	89H90AQ	89H91AQ	89H92AQ
		H=18	89H180AQ	89H181AQ	89H182AQ

Four-hole mounting plate

Pcs/ctn	Color	Height of mounting plate	Item No.		
			Item No.	Item No.	Item No.
200	Nickel plated(A01) Titanium black(A08)	H=0	89H00EQ		
		H=2	89H20EQ		
		H=4	89H40EQ		
		H=9	89H90EQ		
		H=18	89H180EQ		

Up&down cam adjustable mounting plate

Pcs/ctn	Color	Height of mounting plate	Item No.		
			Item No.	Item No.	Item No.
200	Nickel plated(A01) Titanium black(A08)	H=0	89T00TQ	89T01TQ	89T02TQ
		H=2	89T20TQ	89T21TQ	89T22TQ
		H=4	89T40TQ	89T41TQ	89T42TQ
		H=9	89T90TQ	89T91TQ	89T92TQ
		H=18	89T180TQ	89T181TQ	89T182TQ

Up&down cam adjustable mounting plate

Pcs/ctn	Color	Height of mounting plate	Item No.		
			Item No.	Item No.	Item No.
200	Nickel plated(A01) Titanium black(A08)	H=0	85T00TQ	85T01TQ	85T02TQ
		H=2	85T20TQ	85T21TQ	85T22TQ
		H=4	85T40TQ	85T41TQ	85T42TQ

In-line mounting plate

Pcs/ctn	Color	Height of mounting plate	Item No.		
			Item No.	Item No.	Item No.
200	Nickel plated(A01) Titanium black(A08)	H=2	80T20YQ		
		H=4	80T40YQ		

ORDER INFORMATION

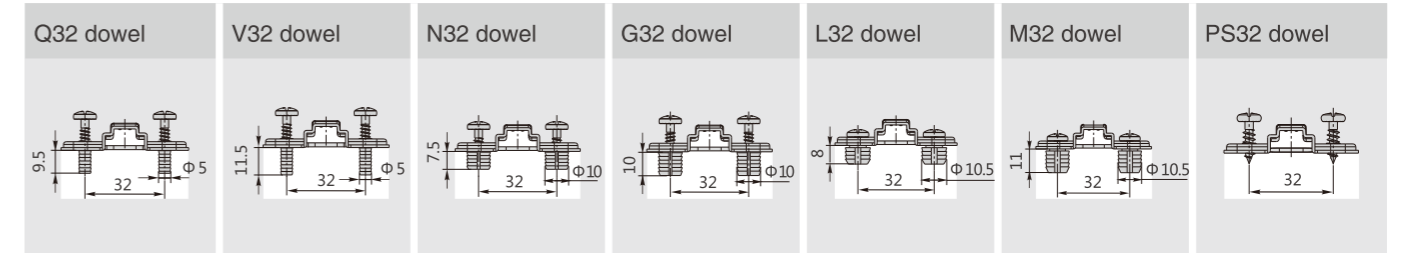

Item No.	Item No.	Item No.	Item No.	Item No.	Item No.	Item No.
89H0QAQ	89H04AQ	89H0NAQ	89H0GAQ	89H0LAQ	89H0MAQ	89H0PAQ
89H2QAQ	89H24AQ	89H2NAQ	89H2GAQ	89H2LAQ	89H2MAQ	89H2PAQ
89H4QAQ	89H44AQ	89H4NAQ	89H4GAQ	89H4LAQ	89H4MAQ	89H4PAQ
89H9QAQ	89H94AQ	89H9NAQ	89H9GAQ	89H9LAQ	89H9MAQ	89H9PAQ
89H18QAQ	89H184AQ	89H18NAQ	89H18GAQ	89H18LAQ	89H18MAQ	89H18PAQ

Item No.	Item No.	Item No.	Item No.	Item No.	Item No.	Item No.

Item No.	Item No.	Item No.	Item No.	Item No.	Item No.	Item No.
89T0QTQ	89T04TQ	89T0NTQ	89T0GTQ	89T0LTQ	89T0MTQ	89T0PTQ
89T2QTQ	89T24TQ	89T2NTQ	89T2GTQ	89T2LTQ	89T2MTQ	89T2PTQ
89T4QTQ	89T44TQ	89T4NTQ	89T4GTQ	89T4LTQ	89T4MTQ	89T4PTQ
89T9QTQ	89T94TQ	89T9NTQ	89T9GTQ	89T9LTQ	89T9MTQ	89T9PTQ
89T18QTQ	89T184TQ	89T18NTQ	89T18GTQ	89T18LTQ	89T18MTQ	89T18PTQ

Item No.	Item No.	Item No.	Item No.	Item No.	Item No.	Item No.
85T0QTQ	85T04TQ	85T0NTQ	85T0GTQ	85T0LTQ	85T0MTQ	85T0PTQ
85T2QTQ	85T24TQ	85T2NTQ	85T2GTQ	85T2LTQ	85T2MTQ	85T2PTQ
85T4QTQ	85T44TQ	85T4NTQ	85T4GTQ	85T4LTQ	85T4MTQ	85T4PTQ

Item No.	Item No.	Item No.	Item No.	Item No.	Item No.	Item No.

ORDER INFORMATION

		S32 dowel		Euro screw	
Mounting plate(snap-on type for frame application)					
		Pcs/ctn 200	Nickel plated(A01) Titanium black(A08)	Height of mounting plate	Item No.
				H=1	88H10JQ
				H=3	88H30JQ
		Pcs/ctn 200	Nickel plated(A01) Titanium black(A08)	H=6	88H60JQ
				H=1	89H10JQ
				H=3	89H30JQ
				H=6	89H60JQ
Opening angle restrictor / Industrial package					
	Dark grey(H11)	Opening angle	85°		
		Item No.	86S80		
		Pcs/ctn	5000		
Decoration cover for hinge cup					
	Nickel plated(A01) Titanium black(A08)	Hinge cup 52mm center	Item No.	G30H	
		Pcs/ctn	3000		
	Nickel plated(A01) Titanium black(A08)	Hinge cup 42/45/48mm center	Item No.	G10H	
		Pcs/ctn	3000		
Decoration cover for hinge arm					
	Nickel plated(A01) Titanium black(A08)	Item No.	S18HH		
		Pcs/ctn	5000		
Wood screw					
	Drilling $\Phi 2$		Item No.	E-140N	
		Pcs/ctn	20000		
	Drilling $\Phi 2$		Item No.	E-160N	
		Pcs/ctn	20000		

ORDER INFORMATION

		Q32 dowel		V32 dowel		N32 dowel		G32 dowel		L32 dowel		M32 dowel		PS32 dowel			
Decoration cover for board($\Phi 35$ mm) / Industrial package																	
		$\Phi 35$	8	White(H03)! Dark grey(H11)													
				Item No.	S35G												
				Pcs/ctn	400												

Assembly

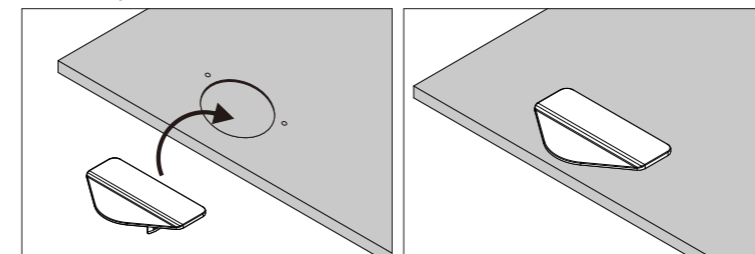



PLANNING

Application with full overlay door

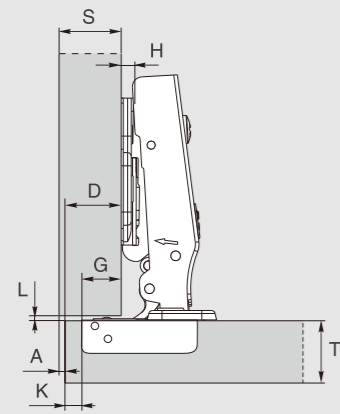

- | | |
|-----------------------------------|----------------------------------|
| S = Thickness of the cabinet side | A = Reveal |
| D = Required door overlay | L = Gap between door and carcass |
| T = Door thickness | H = Height of the mounting plate |
| K = Drilling distance | G = Hinge constant |

Whatever door overlay is required, you can select from our range the combination of both the type of hinge arm and the thickness of mounting plate necessary to solve your construction problem and avoid the need to stock too many different components.

Application with half overlay door

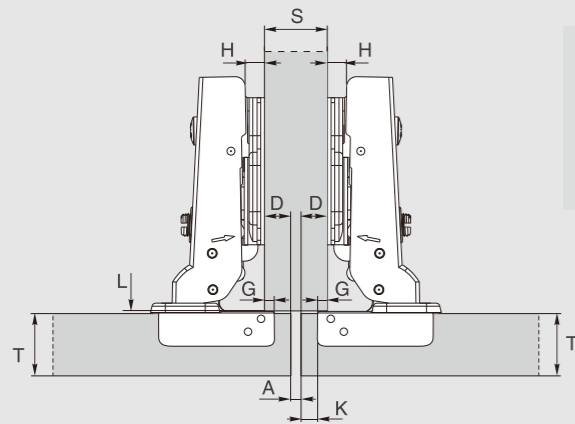

- | | |
|-----------------------------------|----------------------------------|
| S = Thickness of the cabinet side | A = Reveal |
| D = Required door overlay | L = Gap between door and carcass |
| T = Door thickness | H = Height of the mounting plate |
| K = Drilling distance | G = Hinge constant |

Whatever door overlay is required, you can select from our range the combination of both the type of hinge arm and the thickness of mounting plate necessary to solve your construction problem and avoid the need to stock too many different components.

Application with inset door

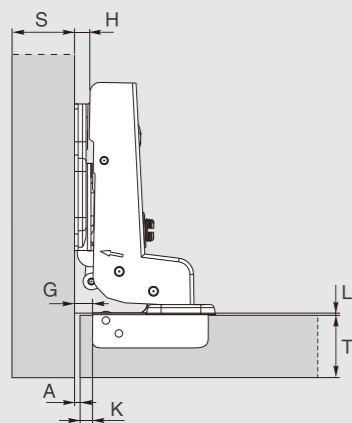

- | | |
|-----------------------------------|---|
| S = Thickness of the cabinet side | L = Gap between internal face of door and internal cabinet elements (e.g. shelves, drawers, etc.) |
| T = Door thickness | H = Height of the mounting plate |
| K = Drilling distance | G = Hinge constant |
| A = Reveal | |

Whatever door overlay is required, you can select from our range the combination of both the type of hinge arm and the thickness of mounting plate necessary to solve your construction problem and avoid the need to stock too many different components.

PLANNING

Simulation of the opening movement of a 110° hinge with full overlay door

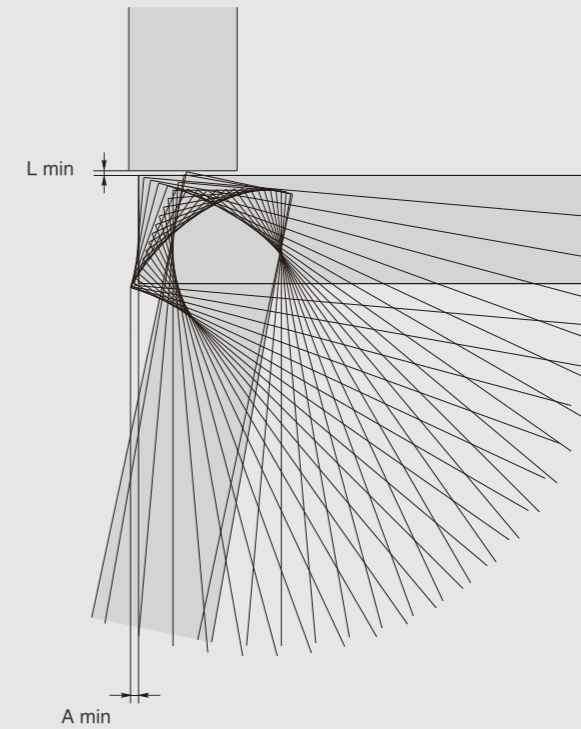

Simulation of the opening movement of a 110° hinge with half overlay door

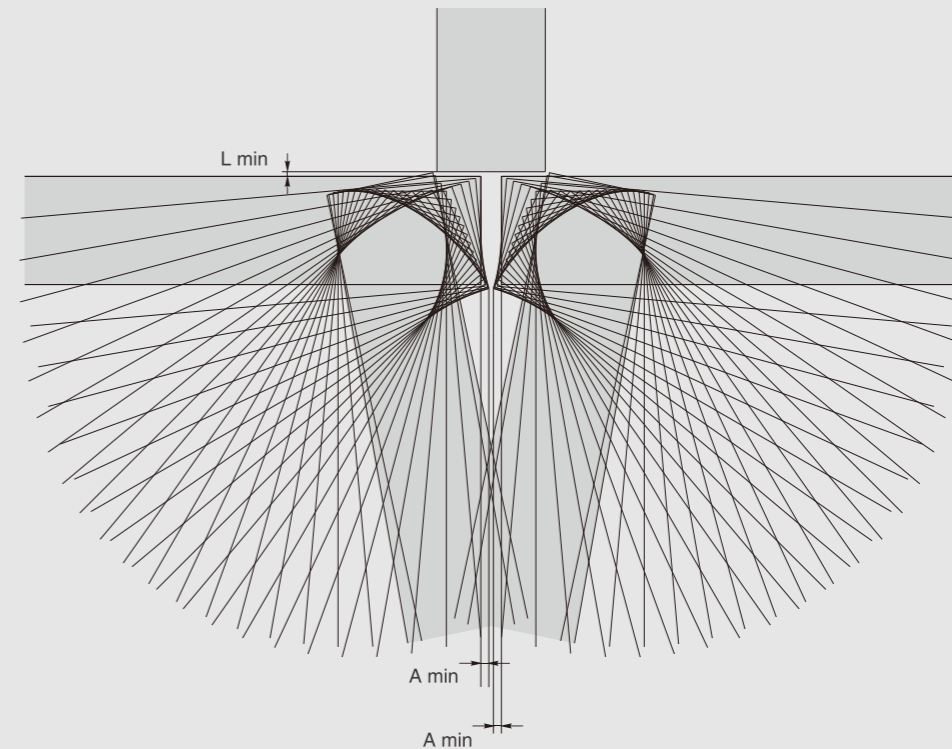



PLANNING

PIVOT-PRO side adjustment

Side adjustment of the door is made by using the indicated screw.

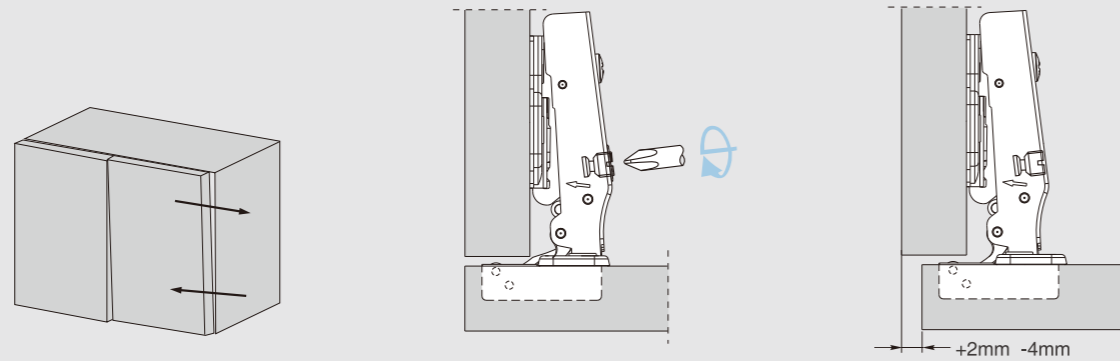

PIVOT-PRO depth adjustment

Depth adjustment is made without loosening any screw. The door can be moved in or out by rotating the cam adjuster on the hinge arm.

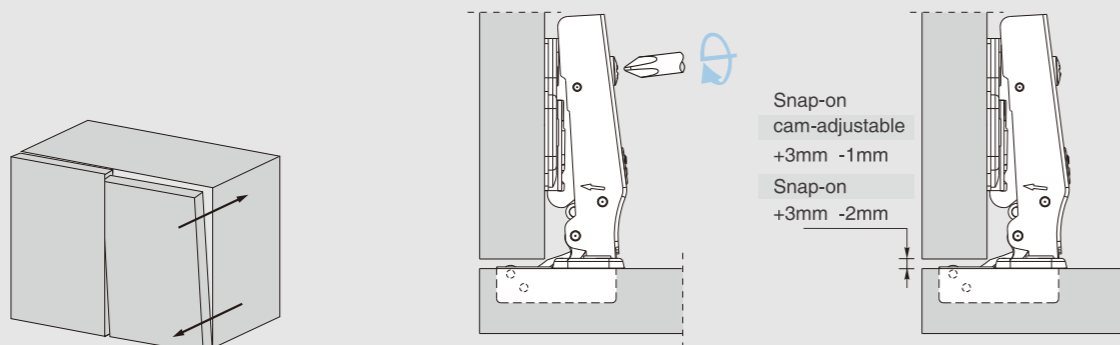

PIVOT-PRO height adjustment

By loosening the two fixing screws to allow the mounting plate to slide up or down, the door can be adjusted vertically by ± 2 mm. After retightening the screws, the depth adjustment is done.

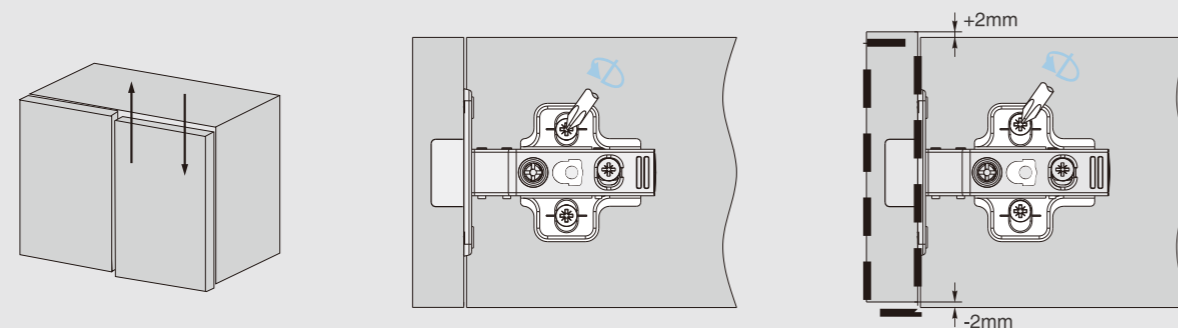

PLANNING

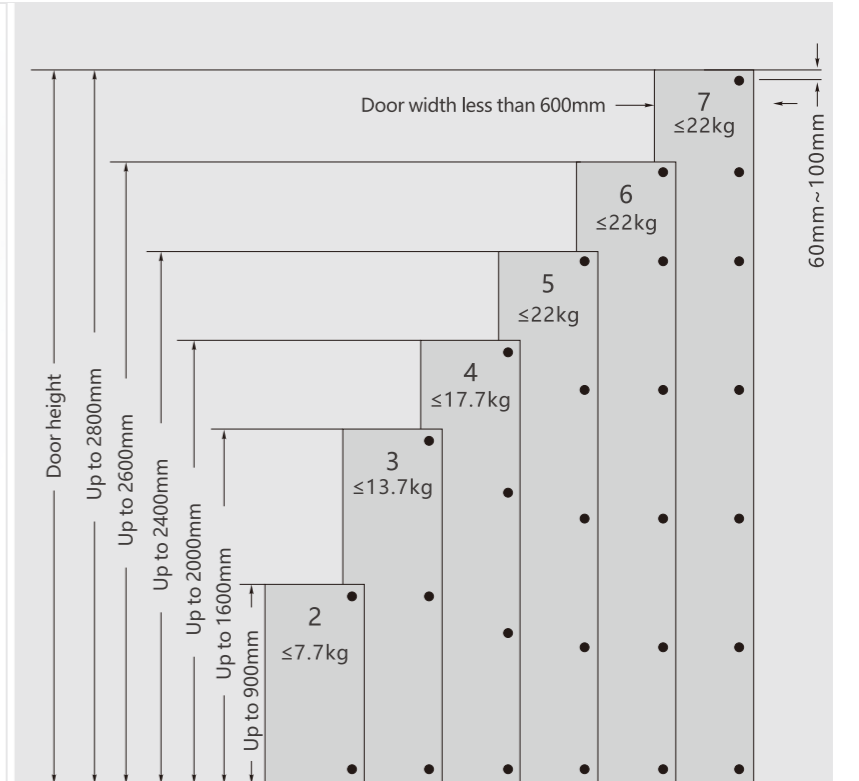
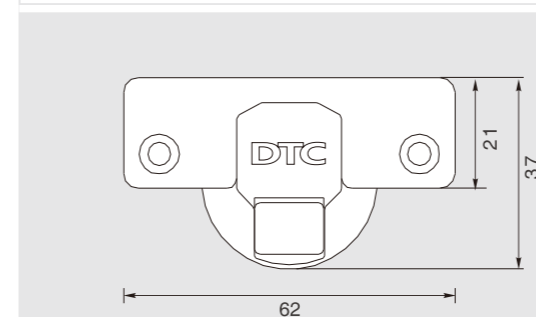

L=distance between hinges, performance is best when L is as far apart as possible

Hinges needed per door

The number of hinges needed depends on three factors: Height, Width and Weight of the door. This illustration can be used as a general guide, however a trial is suggested for doors made of heavier materials. Performance is best when distance (L) is as far apart as possible on doors with two hinges. This is especially important for doors that are wider than they are tall to prevent door sag.

Adjustment

Side adjustment: $4\text{mm} \sim +2\text{mm}$
 Height adjustment: $\pm 2\text{mm}$
 Depth adjustment: Snap-on $-2\text{mm} \sim +3\text{mm}$, Snap-on (Cam adjustable) $-1\text{mm} \sim +3\text{mm}$

Mounting plates

Two-hole and four-hole mounting plates
 Up&down cam adjustable mounting plates