

DOUBLE-WALL DRAWER

DOUBLE-WALL

Side rails + ground glass box-sides

A Gorgeous High Drawer



- A smooth movement, a gentle soft-closing, a convenient storage plus an elegant shape are the basic characteristics of DTC double-wall drawer system. Equipped with specific railings and glass box-sides, a low drawer may become a high drawer with dividing system.
- The combination of side rails and ground glass box-side brings a gorgeous high drawer while the corresponding dividing system provides great convenience for storage.
- The highly stable drawer construction ensures stable and smooth motion with soft closing for wide and high drawers.



Quietness



Intelligence



Durability



Eco-Friendliness

DOUBLE-WALL DRAWER

M00 Series Double-wall Drawer System
(N Height: Lower Drawer)

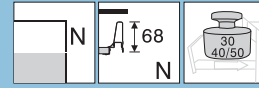

PRODUCT



DESCRIPTION

- Concealed, full extension
- Dynamic load capacity: 30/40/50kg
- Tool free assembly and removal of drawer
- Silent system guarantees smooth run without noise
- Up&down adjustment, left&right adjustment
- Finish: White(E01), silver grey(E18), stainless steel(F04)

SPACE REQUIREMENT

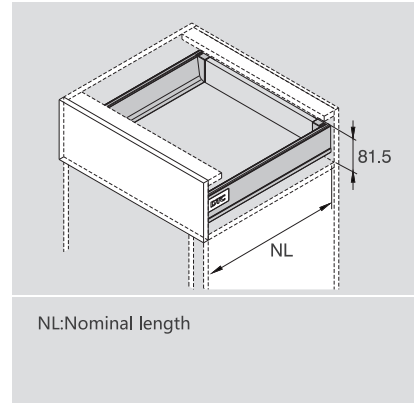

PLANNING

Installation Dimensions(mm)

NL=Nominal Slide Length
LT=Internal Cabinet Depth
LT=NL+3

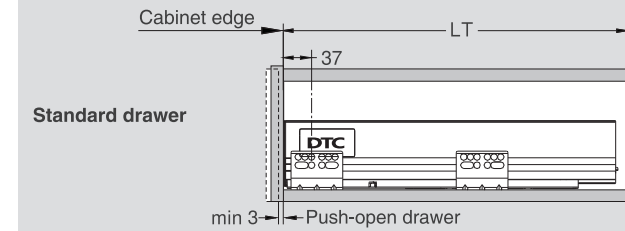

Cabinet Configuration

Cabinet widths/KB(mm)	Cabinet widths/KB(mm)	Stabilizer recommended
300		
350		
400		
450		
500		
600		
800	800	
900	900	
1000	1000	
1200	1200	

LOWER DRAWER FOR WOOD DRAWER BACK

Kit Package				
White(E01) Silver Grey(E18) Stainless Steel(F04)				
NL	Soft Close item No.	Push-open item No.	Set/ctn	
400mm	M00400A	M30400A	1	
450mm	M00450A	M30450A	1	
500mm	M00500A	M30500A	1	
550mm	M00550A	M30550A	1	

1 Slides (left/right) / Industrial Package				
Pre-zinc Steel (F02)				
NL	Soft Close item No.	Push-open item No.	Set/ctn	
400mm	M004004H	M304004H	5	
450mm	M004504H	M304504H	5	
500mm	M005004H	M305004H	5	
550mm	M005504H	M305504H	5	

2 Drawer Sides and Cover Caps (left/right) /Industrial Package			
White(E01) Silver Grey(E18) Stainless Steel(F04)			
NL	Item No.	Set/ctn	
400mm	M00400	5	
450mm	M00450	5	
500mm	M00500	5	
550mm	M00550	5	

4 Front Fixing-brackets (left/right) /Industrial Package			
Zinc Plated (B01)			
	Item No.	Set/ctn	
Screw-on	M00011	120	
Press-in	M00016	120	

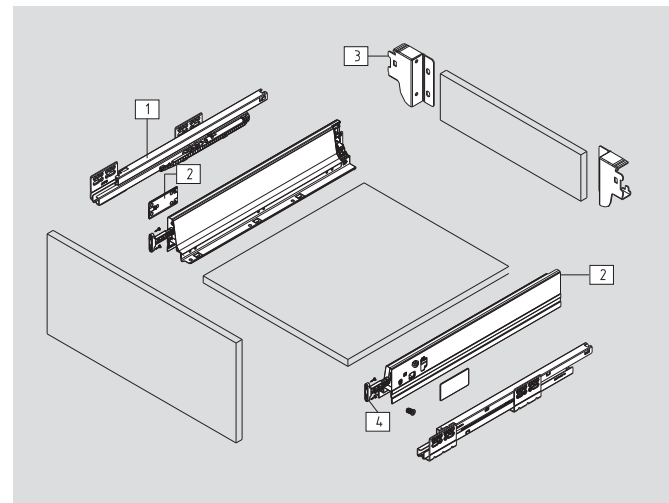

3 Back Fixing-brackets (left/right) /Industrial Package			
White(E01) Silver Grey(E18) Chrome Plated(C01)			
	Item No.	Set/ctn	
	M00031	60	

Screw Positions of the Slides(mm)

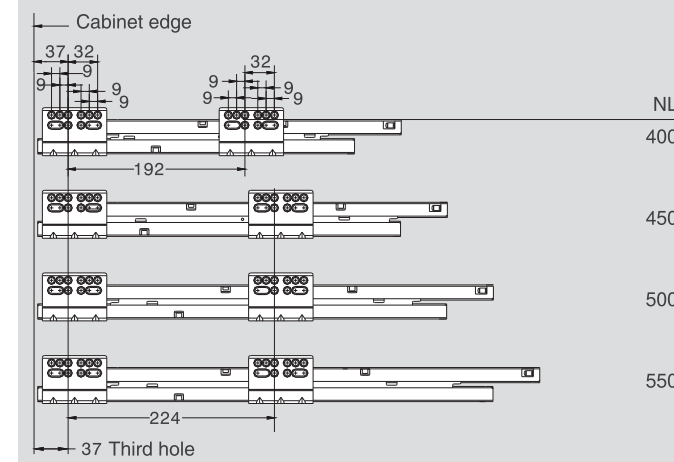

Installation Dimensions(mm)

LW=Internal Cabinet Width

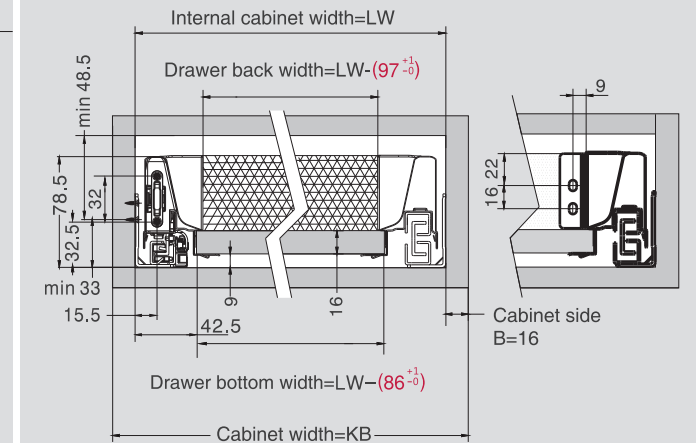

Drawer Front, Back and Bottom Dimensions(mm)

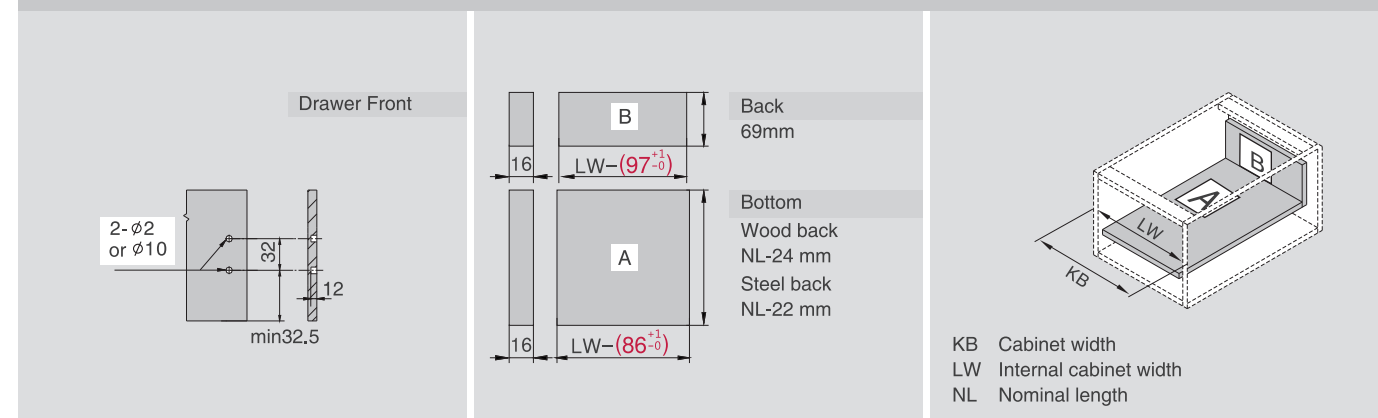

DOUBLE-WALL DRAWER

M01 Series Double-wall Drawer System
(M Height: Lower Drawer)

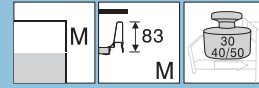

PRODUCT



DESCRIPTION

- Concealed, full extension
- Dynamic load capacity: 30/40/50kg
- Tool free assembly and removal of drawer
- Silent system guarantees smooth run without noise
- Up&down adjustment, left&right adjustment
- Finish: White(E01), silver grey(E18), stainless steel(F04)

SPACE REQUIREMENT

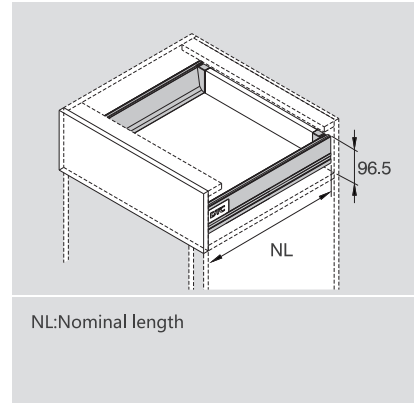

PLANNING

Installation Dimensions(mm)

NL=Nominal Slide Length
LT=Internal Cabinet Depth
LT=NL+3

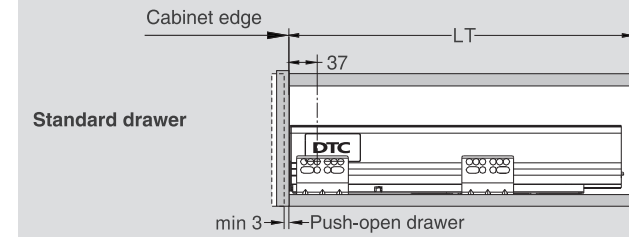

Cabinet Configuration

Cabinet widths/KB(mm)	Cabinet widths/KB(mm)	Stabilizer recommended
300		
350		
400		
450		
500		
600		
800	800	
900	900	
1000	1000	
1200	1200	

LOWER DRAWER FOR WOOD DRAWER BACK

Kit Package				
White(E01) Silver Grey(E18) Stainless Steel(F04)				
NL	Soft Close item No.	Push-open item No.	Set/ctn	
270mm	M01270A	M31270A	1	
300mm	M01300A	M31300A	1	
350mm	M01350A	M31350A	1	
400mm	M01400A	M31400A	1	
450mm	M01450A	M31450A	1	
500mm	M01500A	M31500A	1	
550mm	M01550A	M31550A	1	

1 Slides (left/right) /Industrial Package				
Pre-zinc Steel (F02)				
NL	Soft Close item No.	Push-open item No.	Set/ctn	
270mm	M01270H	M31270H	5	
300mm	M01300H	M31300H	5	
350mm	M01350H	M31350H	5	
400mm	M01400H	M31400H	5	
450mm	M01450H	M31450H	5	
500mm	M01500H	M31500H	5	
550mm	M01550H	M31550H	5	

2 Drawer Sides and Cover Caps (left/right) /Industrial Package			
White(E01) Silver Grey(E18) Stainless Steel(F04)			
NL	Item No.	Set/ctn	
270mm	M01270	5	
300mm	M01300	5	
350mm	M01350	5	
400mm	M01400	5	
450mm	M01450	5	
500mm	M01500	5	
550mm	M01550	5	

4 Front Fixing-brackets (left/right) /Industrial Package			
Zinc Plated (B01)			
	Item No.	Set/ctn	
Screw-on	M01011	120	
Press-in	M01016	120	

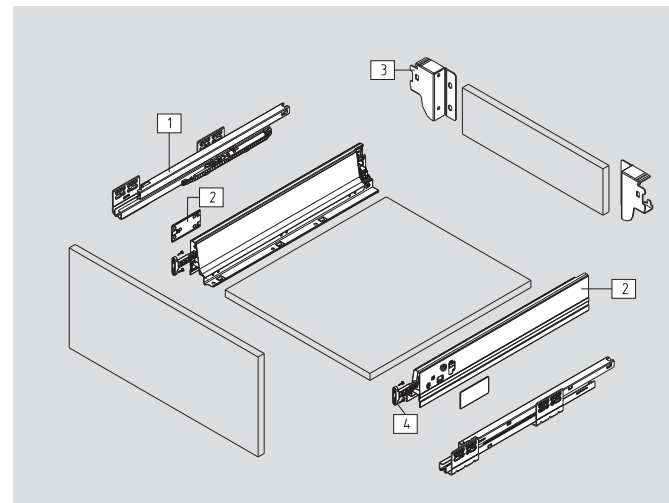

3 Back Fixing-brackets (left/right) /Industrial Package			
White(E01) Silver Grey(E18) Chrome Plated(C01)			
	Item No.	Set/ctn	
	M01031	60	

Screw Positions of the Slides(mm)

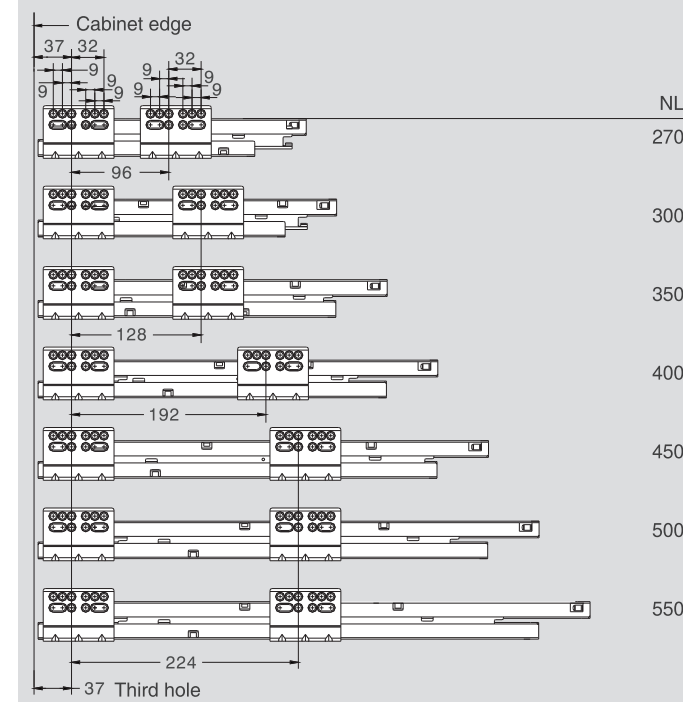

Installation Dimensions(mm)

LW=Internal Cabinet Width

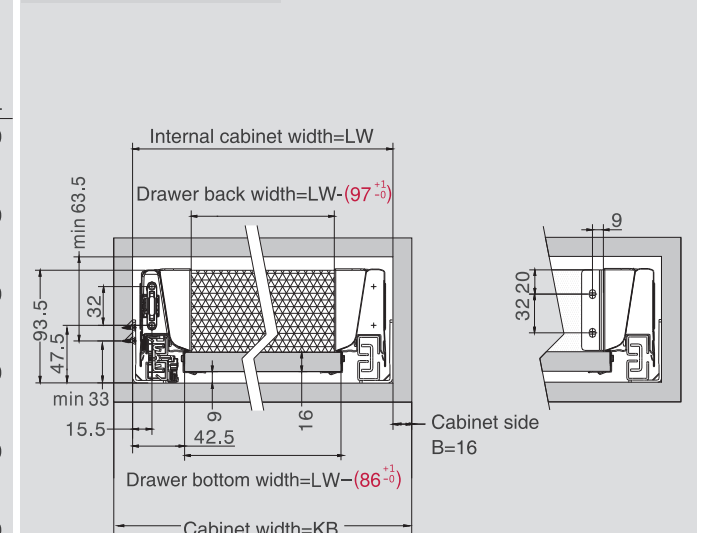

Drawer Front, Back and Bottom Dimensions(mm)

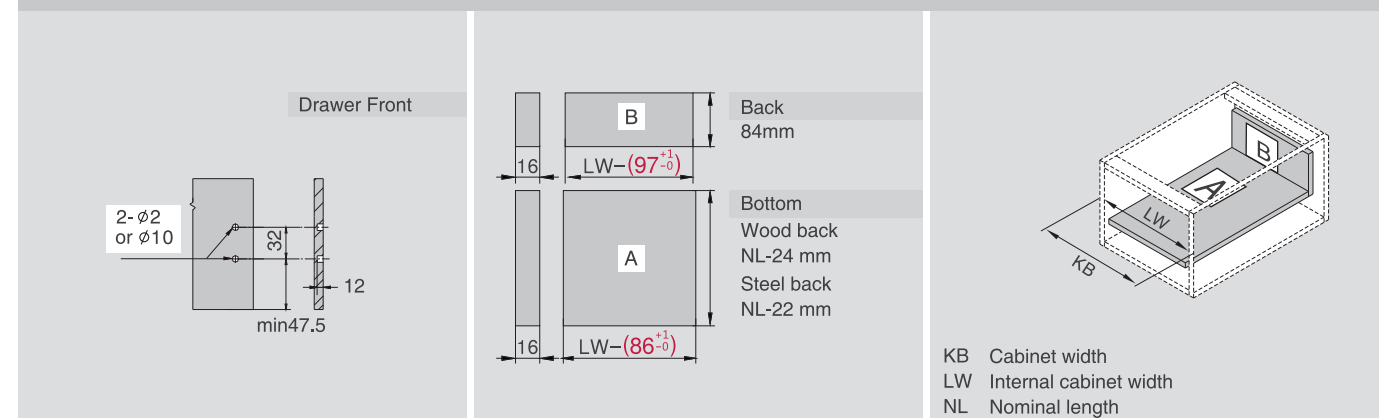

DOUBLE-WALL DRAWER

M01 Series Double-wall Drawer System
(M Height: Lower Inner Drawer)

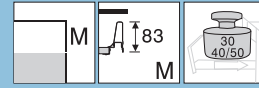

PRODUCT



DESCRIPTION

- Concealed, full extension
- Dynamic load capacity: 30/40/50kg
- Tool free assembly and removal of drawer
- Silent system guarantees smooth run without noise
- Up&down adjustment, left&right adjustment
- Finish: White(E01), silver grey(E18), stainless steel(F04)

SPACE REQUIREMENT

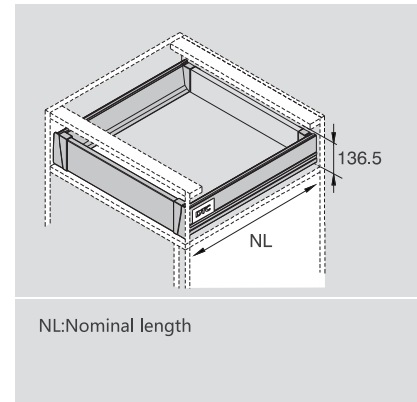

PLANNING

Installation Dimensions(mm)

NL=Nominal Slide Length
LT=Internal Cabinet Depth
Soft close slides LT=NL+3
Push-open slides LT=NL+12

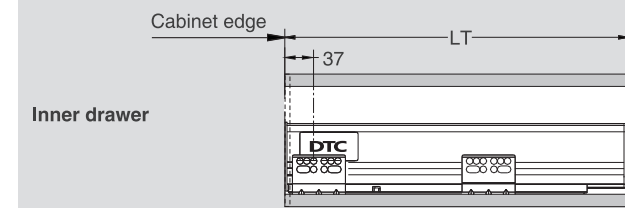

Cabinet Configuration

Cabinet widths/KB(mm)	Cabinet widths/KB(mm)	Stabilizer recommended
300		
350		
400		
450		
500		
600		
800	800	
900	900	
1000	1000	
1200	1200	

LOWER INNER DRAWER FOR WOOD DRAWER BACK

Kit Package				
White(E01)!Silver Grey(E18)!Stainless Steel(F04)				
NL	Soft Close item No.	Push-open item No.	Set /ctn	
270mm	M01270Q	M31270Q	1	
300mm	M01300Q	M31300Q	1	
350mm	M01350Q	M31350Q	1	
400mm	M01400Q	M31400Q	1	
450mm	M01450Q	M31450Q	1	
500mm	M01500Q	M31500Q	1	
550mm	M01550Q	M31550Q	1	

1 Slides (left/right) /Industrial Package				
Pre-zinc Steel (F02)				
NL	Soft Close item No.	Push-open item No.	Set /ctn	
270mm	M01270H	M31270H	5	
300mm	M01300H	M31300H	5	
350mm	M01350H	M31350H	5	
400mm	M01400H	M31400H	5	
450mm	M01450H	M31450H	5	
500mm	M01500H	M31500H	5	
550mm	M01550H	M31550H	5	

2 Drawer Sides and Cover Caps (left/right) /Industrial Package		
White(E01)!Silver Grey(E18)!Stainless Steel(F04)		
NL	Item No.	Set/ctn
270mm	M01270	5
300mm	M01300	5
350mm	M01350	5
400mm	M01400	5
450mm	M01450	5
500mm	M01500	5
550mm	M01550	5

3 Back Fixing-brackets (left/right) /Industrial Package	
White(E01)!Silver Grey(E18)!Chrome Plated(C01)	
Item No.	Set/ctn
M01031	60

4 Front Fixing-brackets (left/right) /Industrial Package	
White(H03)!Grey(H11)	
Item No.	Set/ctn
M01012	60

5 Front Section / Industrial Package /For cutting to size,1100mm. Cutting:Internal cabinet width LW-97	
White(E01)!Silver Grey(E18)	
Item No.	Pcs/ctn
M01021	20

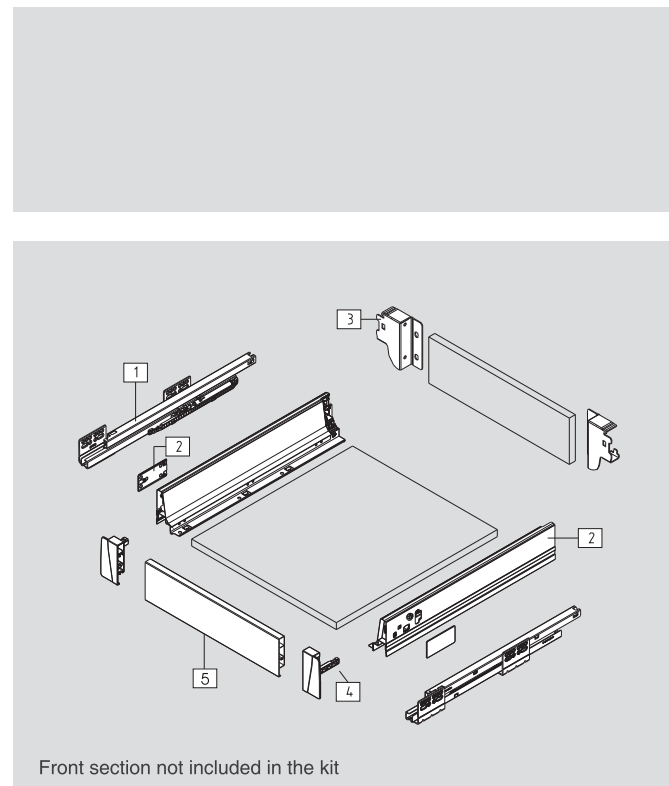

Screw Positions of the Slides(mm)

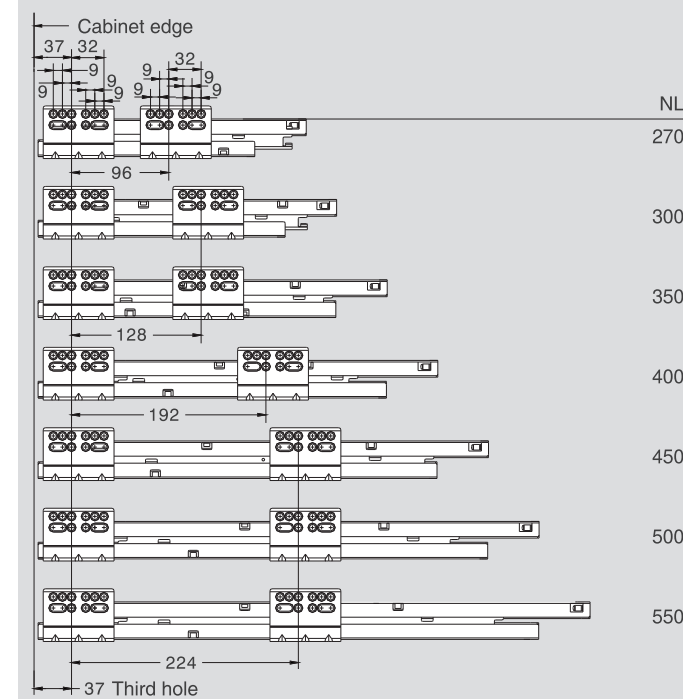

Fixing Hole Position for Push-open Inner Drawer(mm)

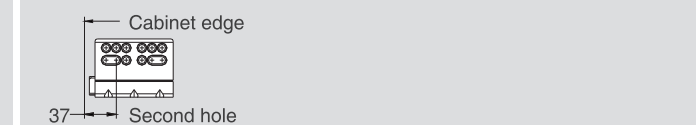

Installation Dimensions(mm)

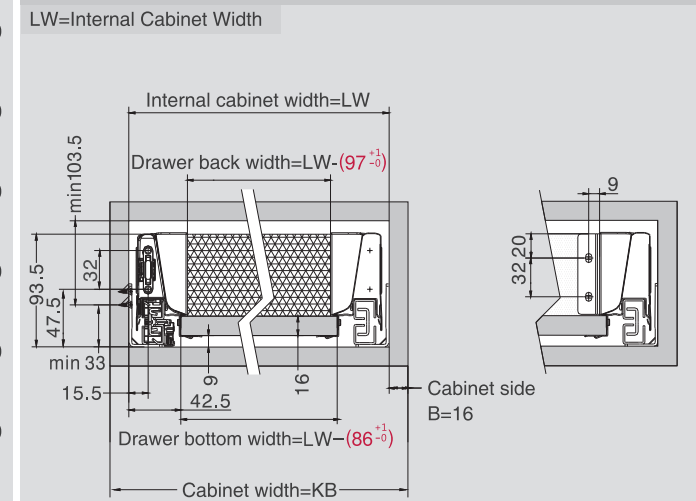

Drawer Front, Back and Bottom Dimensions(mm)

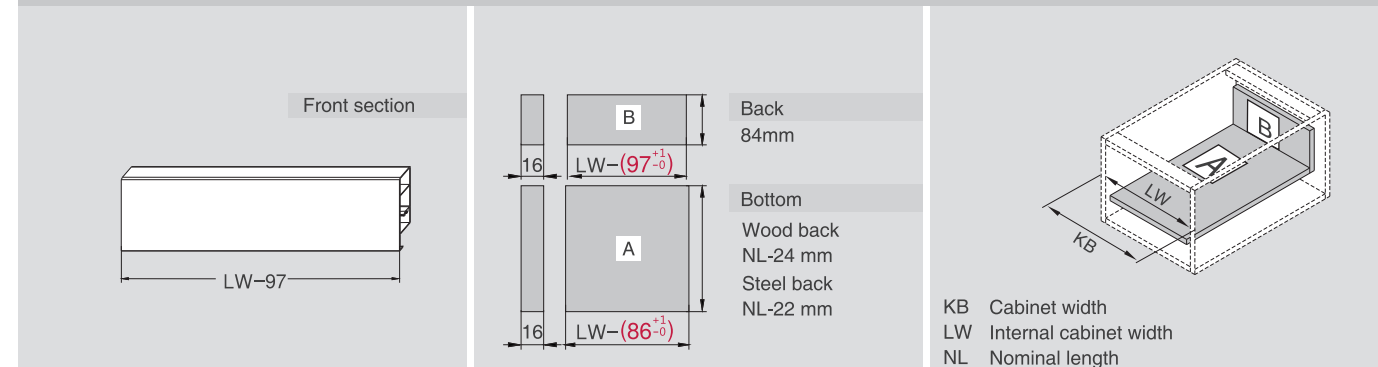

DOUBLE-WALL DRAWER

M02 Series Double-wall Drawer System
(K Height: Lower Drawer)



PRODUCT



DESCRIPTION

- Concealed, full extension
- Dynamic load capacity: 30/40/50kg
- Tool free assembly and removal of drawer
- Silent system guarantees smooth run without noise
- Up&down adjustment, left&right adjustment
- Finish: White(E01), silver grey(E18), stainless steel(F04)

SPACE REQUIREMENT

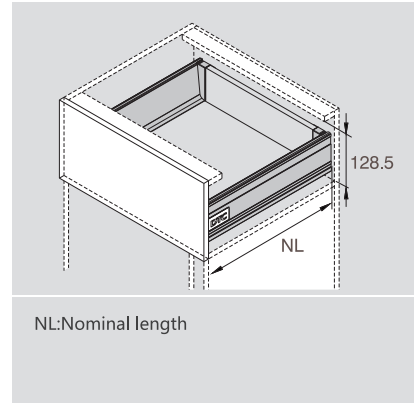

PLANNING

Installation Dimensions(mm)

NL=Nominal Slide Length
LT=Internal Cabinet Depth
LT=NL+3

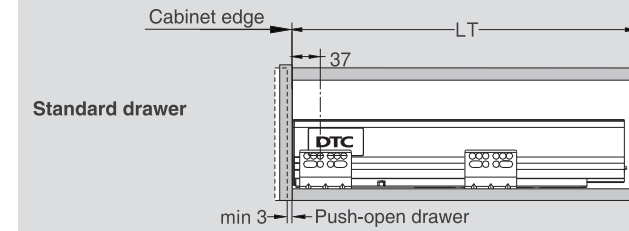

Cabinet Configuration

Cabinet widths/KB(mm)	Cabinet widths/KB(mm)	Stabilizer recommended
300		
350		
400		
450		
500		
600		
800	800	
900	900	
1000	1000	
1200	1200	

LOWER DRAWER FOR WOOD DRAWER BACK

Kit Package			
White(E01)!Silver Grey(E18)!Stainless Steel(F04)			
NL	Soft Close item No.	Push-open item No.	Set /ctn
400mm	M02400A	M32400A	1
450mm	M02450A	M32450A	1
500mm	M02500A	M32500A	1
550mm	M02550A	M32550A	1
600mm	M02600A	M32600A	1

1 Slides (left/right) /Industrial Package			
Pre-zinc Steel (F02)			
NL	Soft Close item No.	Push-open item No.	Set /ctn
400mm	M01400H	M31400H	5
450mm	M01450H	M31450H	5
500mm	M01500H	M31500H	5
550mm	M01550H	M31550H	5
600mm	M01600H	M31600H	5

2 Drawer Sides and Cover Caps (left/right) /Industrial Package		
White(E01)!Silver Grey(E18)!Stainless Steel(F04)		
NL	Item No.	Set/ctn
400mm	M02400	5
450mm	M02450	5
500mm	M02500	5
550mm	M02550	5
600mm	M02600	5

3 Back Fixing-brackets (left/right) /Industrial Package	
White(E01)!Silver Grey(E18)!Chrome Plated(C01)	
Item No.	Set/ctn
M02031	60

4 Front Fixing-brackets (left/right) /Industrial Package	
Zinc Plated (B01)	
Item No.	Set/ctn
Screw-on M01011	120
Press-in M01016	120

5 Front Fixing-brackets /Industrial Package	
Grey(H11)	
Item No.	Set/ctn
M02014	120

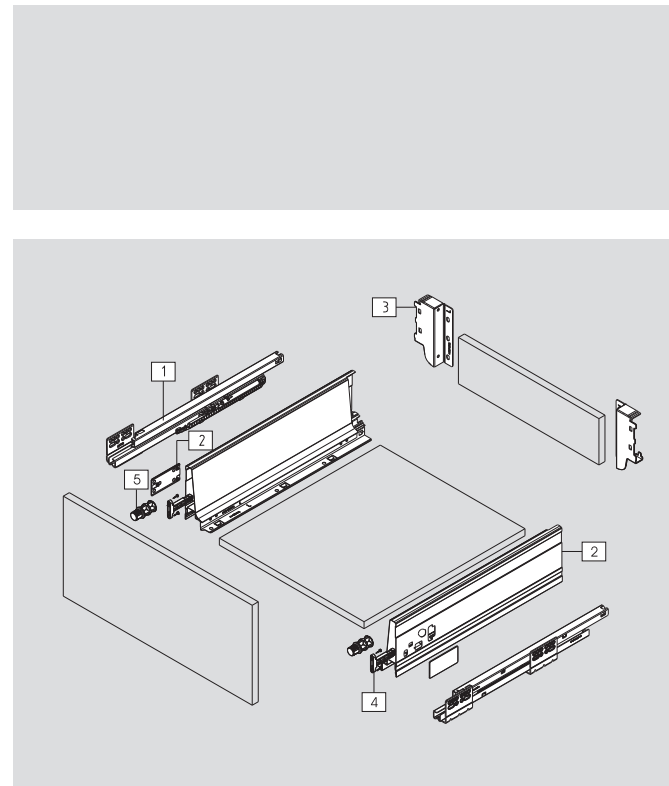

Screw Positions of the Slides(mm)

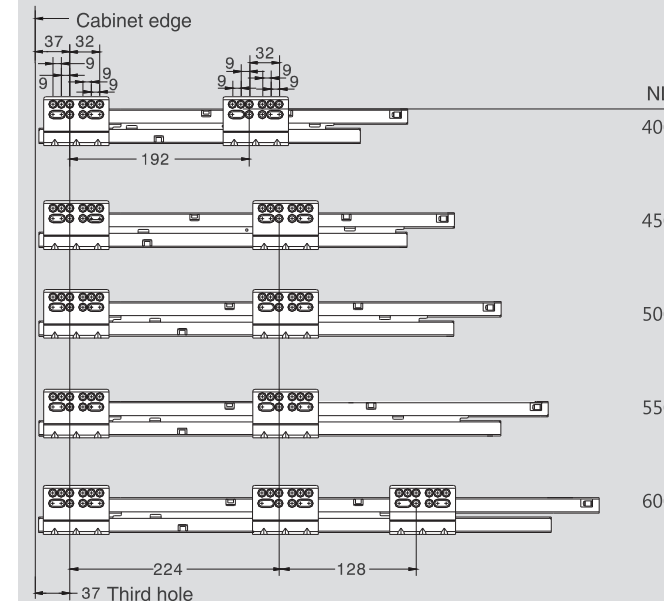

Installation Dimensions(mm)

LW=Internal Cabinet Width

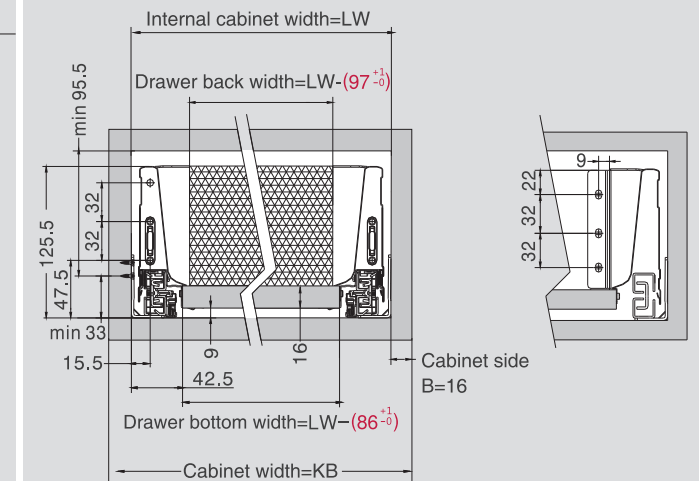

Drawer Front, Back and Bottom Dimensions(mm)

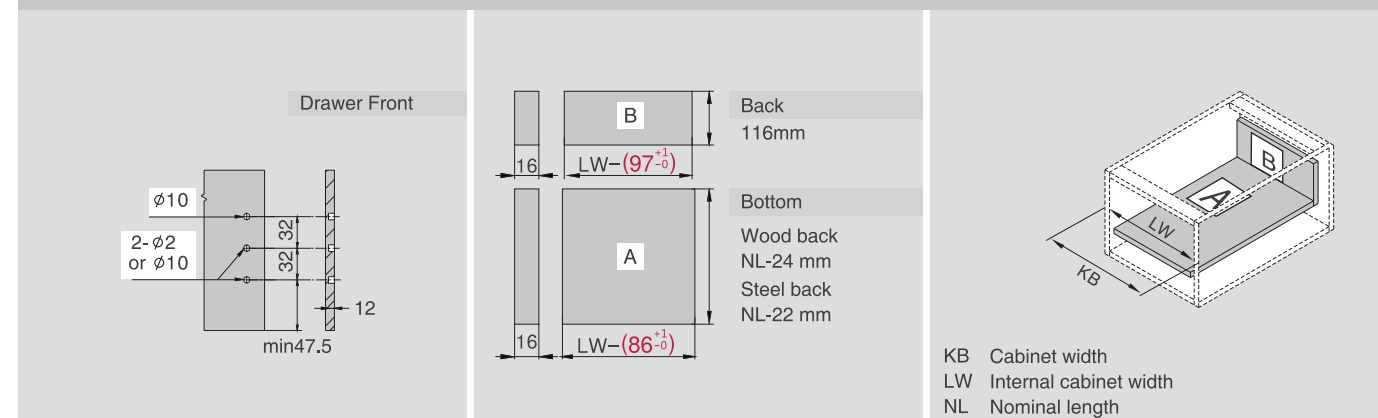

DOUBLE-WALL DRAWER

M02 Series Double-wall Drawer System
(K Height: Lower Inner Drawer)

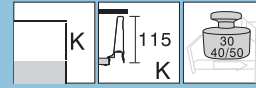

PRODUCT



DESCRIPTION

- Concealed, full extension
- Dynamic load capacity: 30/40/50kg
- Tool free assembly and removal of drawer
- Silent system guarantees smooth run without noise
- Up&down adjustment, left&right adjustment
- Finish: White(E01), silver grey(E18), stainless steel(F04)

SPACE REQUIREMENT

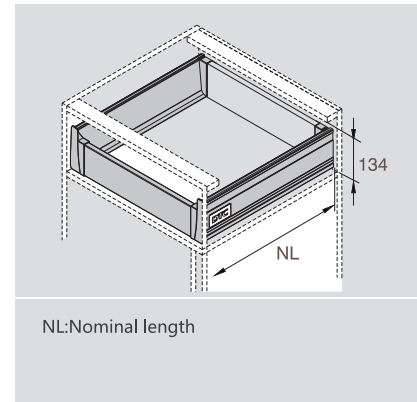

PLANNING

Installation Dimensions(mm)

NL=Nominal Slide Length
LT=Internal Cabinet Depth
Soft close slides LT=NL+3
Push-open slides LT=NL+12

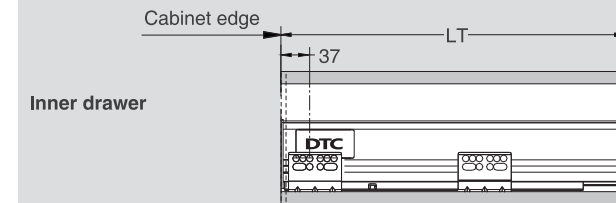

Cabinet Configuration

Cabinet widths/KB(mm)	Cabinet widths/KB(mm)	Stabilizer recommended
300		
350		
400		
450		
500		
600		
800	800	
900	900	
1000	1000	
1200	1200	

LOWER DRAWER FOR WOOD DRAWER BACK

Kit Package				1 Slides (left/right) /Industrial Package				2 Drawer Sides and Cover Caps (left/right) /Industrial Package			
White(E01)!Silver Grey(E18)!Stainless Steel(F04)				Pre-zinc Steel (F02)				White(E01)!Silver Grey(E18)!Stainless Steel(F04)			
NL	Soft Close item No.	Push-open item No.	Set /ctn	NL	Soft Close item No.	Push-open item No.	Set /ctn	NL	Item No.	Set/ctn	
400mm	M02400Q	M32400Q	1	400mm	M01400H	M31400H	5	400mm	M02400	5	
450mm	M02450Q	M32450Q	1	450mm	M01450H	M31450H	5	450mm	M02450	5	
500mm	M02500Q	M32500Q	1	500mm	M01500H	M31500H	5	500mm	M02500	5	
550mm	M02550Q	M32550Q	1	550mm	M01550H	M31550H	5	550mm	M02550	5	
600mm	M02600Q	M32600Q	1	600mm	M01600H	M31600H	5	600mm	M02600	5	

3 Back Fixing-brackets (left/right) /Industrial Package	
White(E01)!Silver Grey(E18)!Chrome Plated(C01)	
Item No.	M02031
Set/ctn	60

4 Front Fixing-brackets (left/right) /Industrial Package	
White(H03)!Grey(H11)	
Item No.	M02010
Set/ctn	60

5 Front Section / Industrial Package /For cutting to size,1100mm. Cutting:Internal cabinet width LW-97	
White(E01)!Silver Grey(E18)	
Item No.	M01021
Pcs/ctn	20

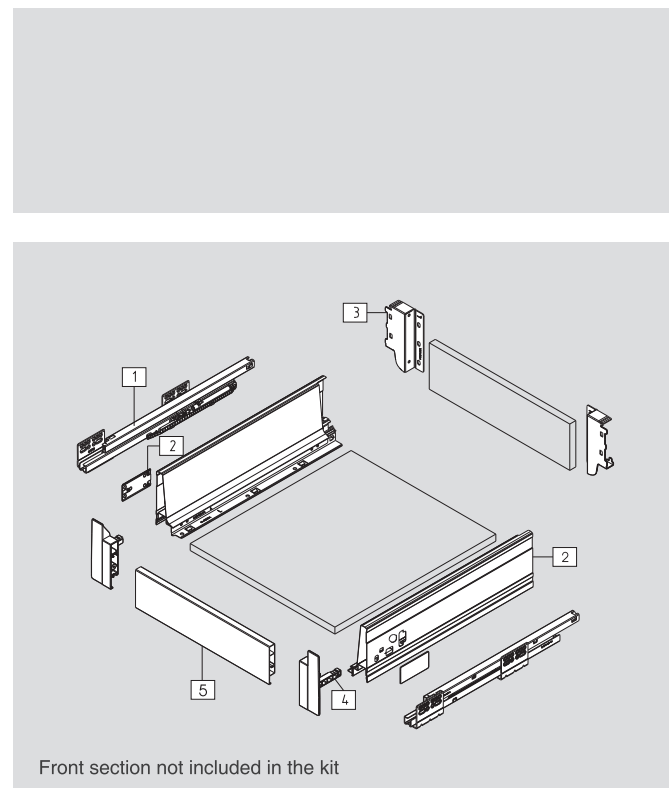

Screw Positions of the Slides(mm)

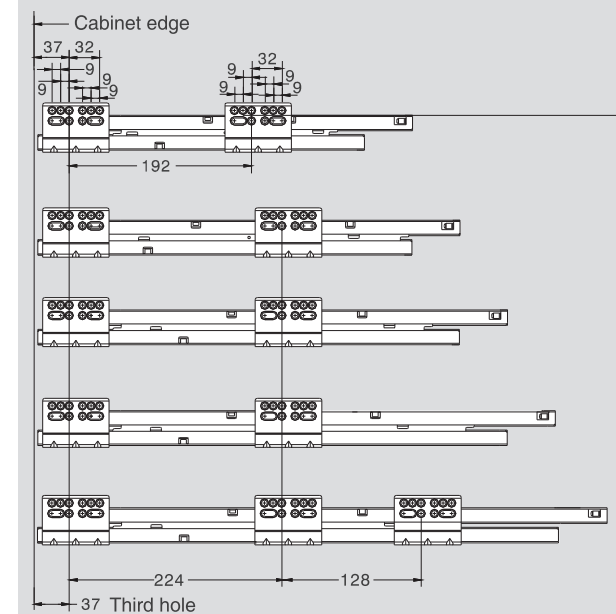

Fixing Hole Position for Push-open Inner Drawer(mm)

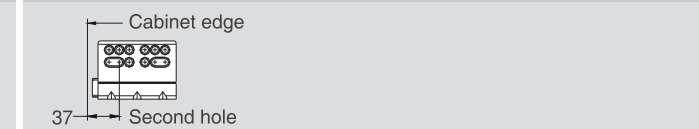

Installation Dimensions(mm)

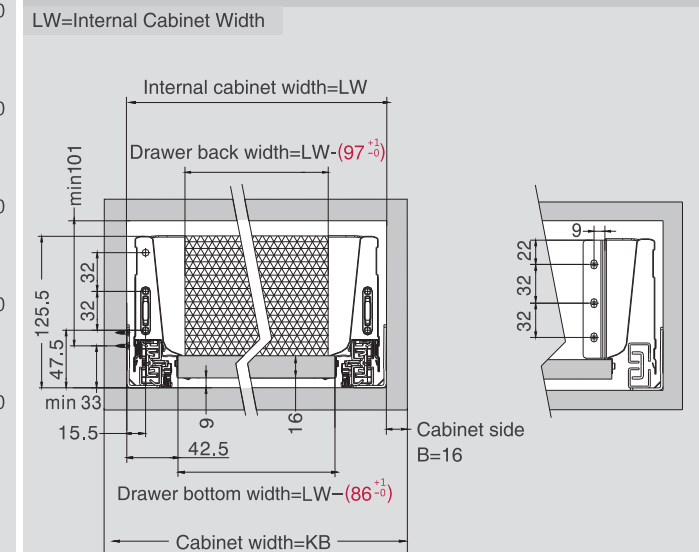

Drawer Front, Back and Bottom Dimensions(mm)

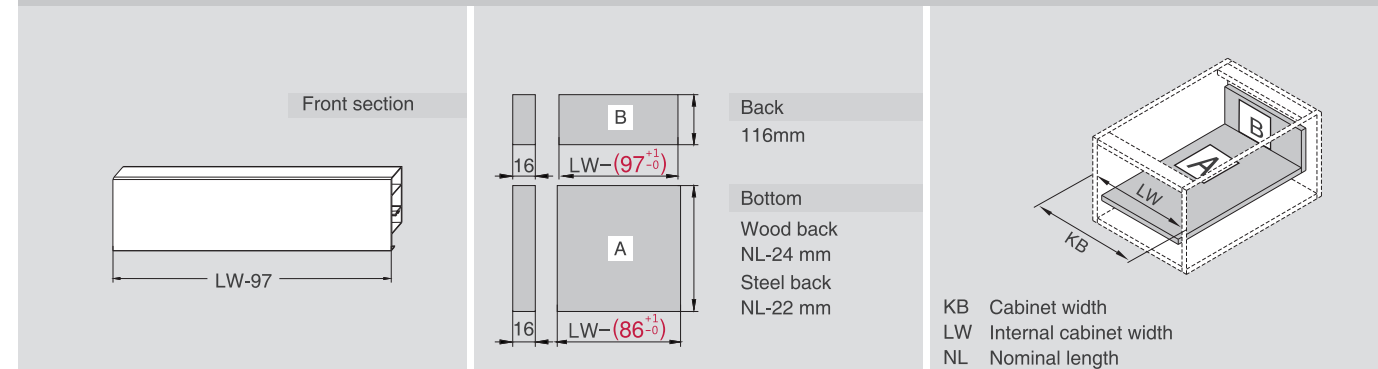

DOUBLE-WALL DRAWER

M01 Series Double-wall Drawer System
(B Height:Medium Drawer)

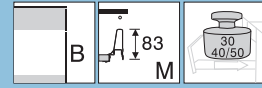

PRODUCT



DESCRIPTION

- Concealed, full extension
- Dynamic load capacity: 30/40/50kg
- Tool free assembly and removal of drawer
- Silent system guarantees smooth run without noise
- Up&down adjustment, left&right adjustment
- Finish:White(E01), silver grey(E18), stainless steel(F04)

SPACE REQUIREMENT

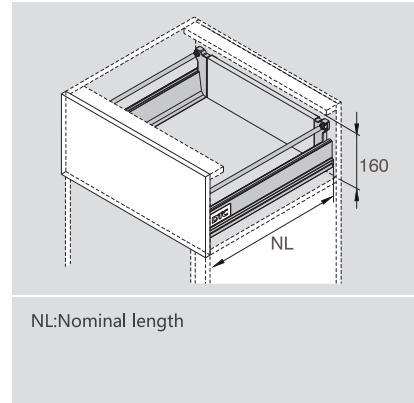

PLANNING

Installation Dimensions(mm)

NL=Nominal Slide Length
LT=Internal Cabinet Depth
LT=NL+3

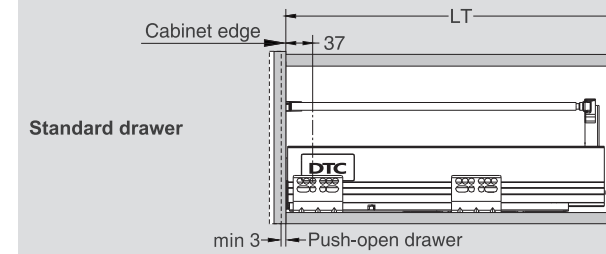

Cabinet Configuration

Cabinet widths/KB(mm)	Cabinet widths/KB(mm)	Stabilizer recommended
300		
350		
400		
450		
500		
600		
800	800	
900	900	
1000	1000	
1200	1200	

MEDIUM DRAWER WITH SINGLE ROUND RAILING FOR WOOD DRAWER BACK

Kit Package				
White(E01)!Silver Grey(E18)!Stainless Steel(F04)				
NL	Soft Close item No.	Push-open item No.	Set/ctn	
350mm	M01350B	M31350B	1	
400mm	M01400B	M31400B	1	
450mm	M01450B	M31450B	1	
500mm	M01500B	M31500B	1	
550mm	M01550B	M31550B	1	

1 Slides (left/right) / Industrial Package				
Pre-zinc Steel (F02)				
NL	Soft Close item No.	Push-open item No.	Set/ctn	
350mm	M01350H	M31350H	5	
400mm	M01400H	M31400H	5	
450mm	M01450H	M31450H	5	
500mm	M01500H	M31500H	5	
550mm	M01550H	M31550H	5	

2 Drawer Sides and Cover Caps (left/right) /Industrial Package			
White(E01)!Silver Grey(E18)!Stainless Steel(F04)			
NL	Item No.	Set/ctn	
350mm	M01350	5	
400mm	M01400	5	
450mm	M01450	5	
500mm	M01500	5	
550mm	M01550	5	

6 Round Side Rails (left/right) /Industrial Package			
White(E01)!Silver Grey(E18)!Chrome Plated(C01)			
NL	Item No.	Set/ctn	
350mm	M01041350	60	
400mm	M01041400	60	
450mm	M01041450	60	
500mm	M01041500	60	
550mm	M01041550	60	

3 Back Fixing-brackets (left/right) /Industrial Package		
White(E01)!Silver Grey(E18)!Chrome Plated(C01)		
Item No.	Set/ctn	
M01032	40	

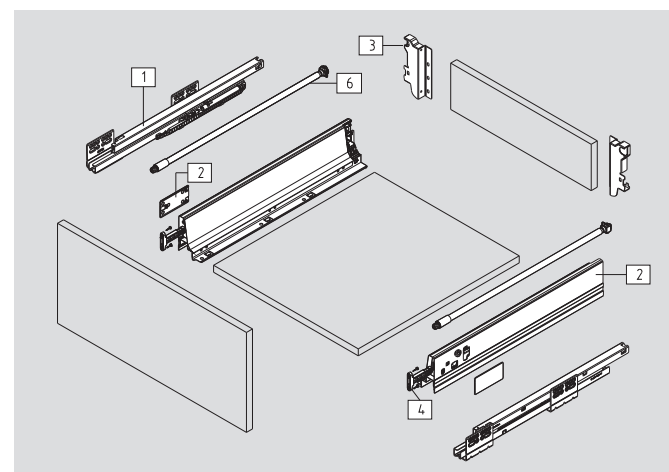

4 Front Fixing-brackets (left/right) /Industrial Package		
Zinc Plated (B01)		
	Item No.	Set/ctn
Screw-on	M01011	120
Press-in	M01016	120

Screw Positions of the Slides(mm)

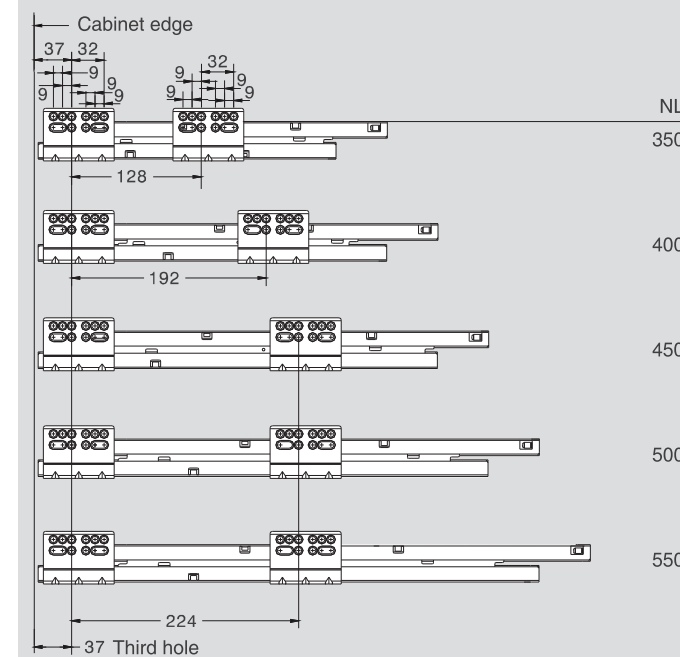

Installation Dimensions(mm)

LW=Internal Cabinet Width

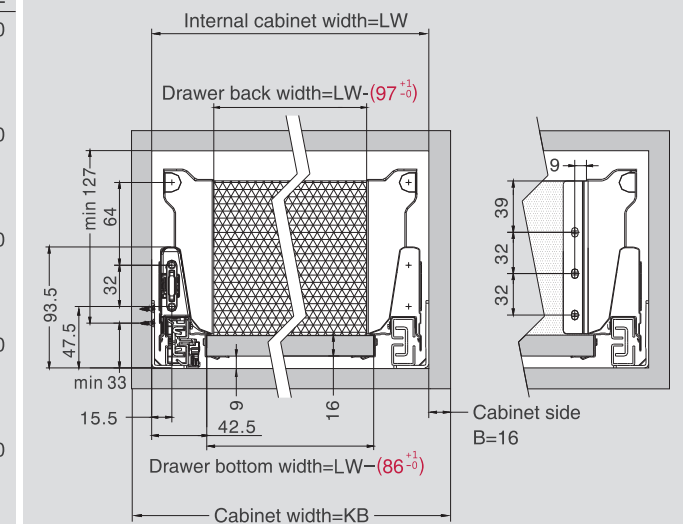

Drawer Front, Back and Bottom Dimensions(mm)

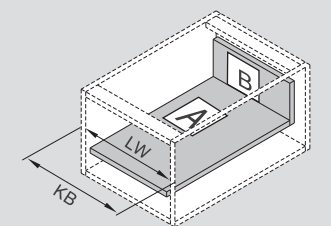
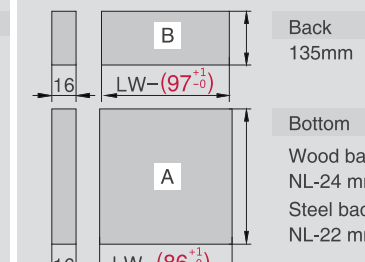
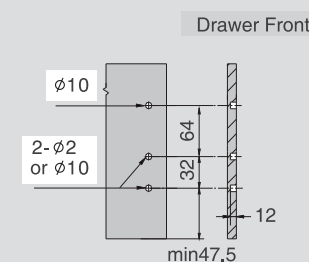

KB Cabinet width
LW Internal cabinet width
NL Nominal length

DOUBLE-WALL DRAWER

M01 Series Double-wall Drawer System
(B Height:Medium Inner Drawer)

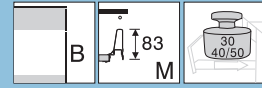

PRODUCT



DESCRIPTION

- Concealed, full extension
- Dynamic load capacity: 30/40/50kg
- Tool free assembly and removal of drawer
- Silent system guarantees smooth run without noise
- Up&down adjustment, left&right adjustment
- Finish:White(E01), silver grey(E18), stainless steel(F04)

SPACE REQUIREMENT

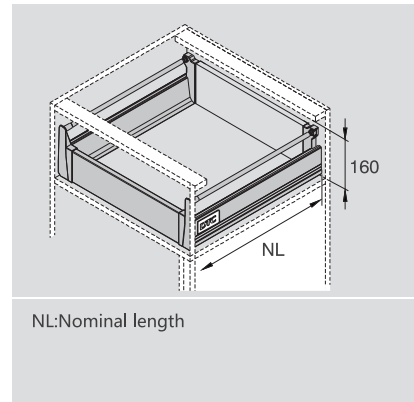

PLANNING

Installation Dimensions(mm)

NL=Nominal Slide Length
LT=Internal Cabinet Depth
Soft close slides LT=NL+3
Push-open slides LT=NL+12

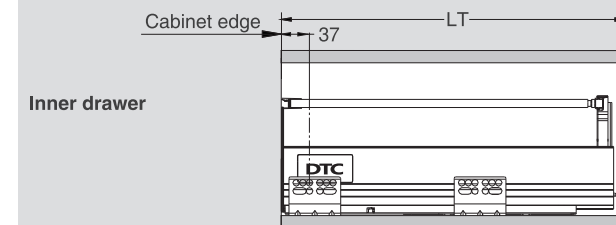

Cabinet Configuration

Cabinet widths/KB(mm)	Cabinet widths/KB(mm)	Stabilizer recommended
300		
350		
400		
450		
500		
600		
800	800	
900	900	
1000	1000	
1200	1200	

MEDIUM INNER DRAWER WITH SINGLE ROUND RAILING FOR WOOD DRAWER BACK

Kit Package				
White(E01)!Silver Grey(E18)!Stainless Steel(F04)				
NL	Soft Close item No.	Push-open item No.	Set/ctn	
350mm	M01350R	M31350R	1	
400mm	M01400R	M31400R	1	
450mm	M01450R	M31450R	1	
500mm	M01500R	M31500R	1	
550mm	M01550R	M31550R	1	

1 Slides (left/right) / Industrial Package				
Pre-zinc Steel (F02)				
NL	Soft Close item No.	Push-open item No.	Set/ctn	
350mm	M01350H	M31350H	5	
400mm	M01400H	M31400H	5	
450mm	M01450H	M31450H	5	
500mm	M01500H	M31500H	5	
550mm	M01550H	M31550H	5	

2 Drawer Sides and Cover Caps (left/right) /Industrial Package			
White(E01)!Silver Grey(E18)!Stainless Steel(F04)			
NL	Item No.	Set/ctn	
350mm	M01350	5	
400mm	M01400	5	
450mm	M01450	5	
500mm	M01500	5	
550mm	M01550	5	

6 Round Side Rails (left/right) /Industrial Package			
White(E01)!Silver Grey(E18)!Chrome Plated(C01)			
NL	Item No.	Set/ctn	
350mm	M0104F350	60	
400mm	M0104F400	60	
450mm	M0104F450	60	
500mm	M0104F500	60	
550mm	M0104F550	60	

3 Back Fixing-brackets (left/right) / Industrial Package			
White(E01)!Silver Grey(E18)!Chrome Plated(C01)			
Item No.	Set/ctn		
M01032	40		

4 Front Fixing-brackets (left/right) / Industrial Package			
White(H03)!Grey(H11)			
Item No.	Set/ctn		
M01013	40		

5 Front Section / Industrial Package			
/For cutting to size,1100mm.			
Cutting:Internal cabinet width LW-97			
White(E01)!Silver Grey(E18)			
Item No.	Set/ctn		
M01021	20		

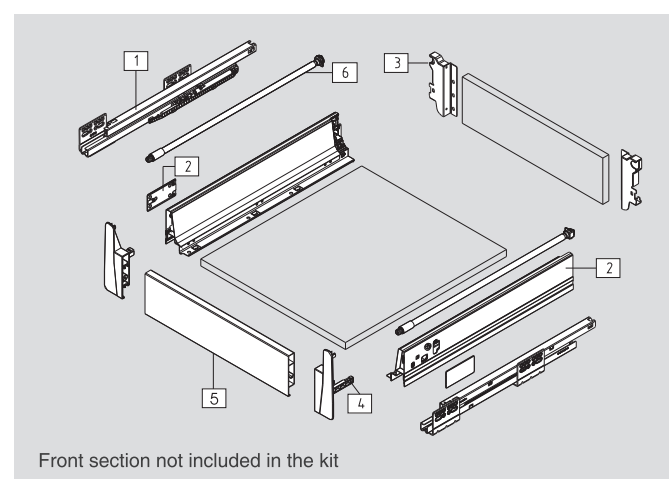

Screw Positions of the Slides(mm)

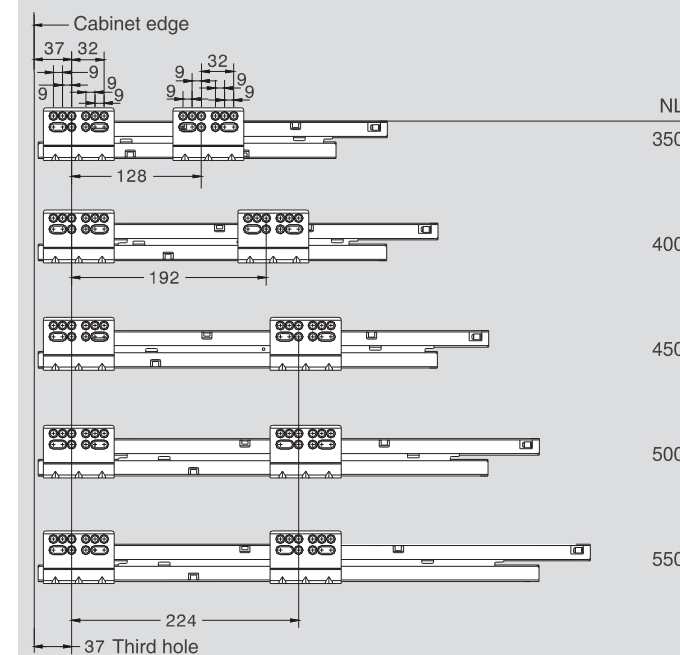

Fixing Hole Position for Push-open Inner Drawer(mm)

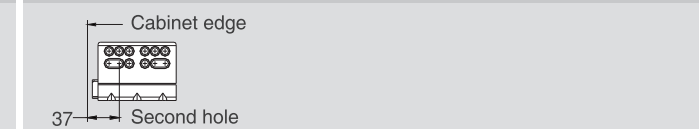

Installation Dimensions(mm)

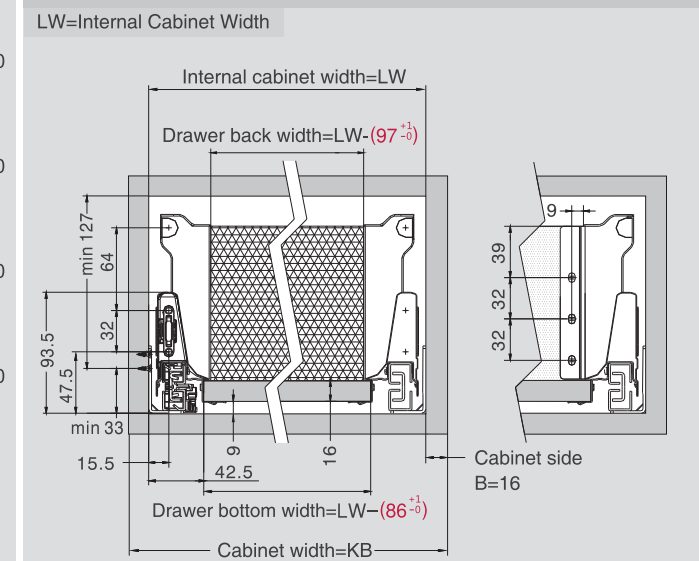

Drawer Front, Back and Bottom Dimensions(mm)

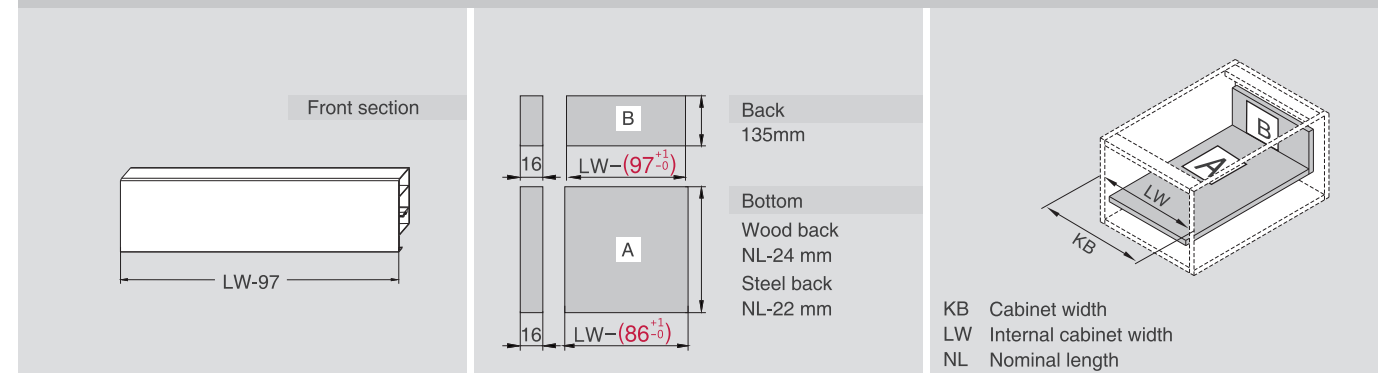

DOUBLE-WALL DRAWER

M02 Series Double-wall Drawer System
(C Height:Medium Drawer)

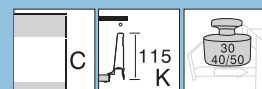

PRODUCT



DESCRIPTION

- Concealed, full extension
- Dynamic load capacity: 30/40/50kg
- Tool free assembly and removal of drawer
- Silent system guarantees smooth run without noise
- Up&down adjustment, left&right adjustment
- Finish:White(E01), silver grey(E18), stainless steel(F04)

SPACE REQUIREMENT

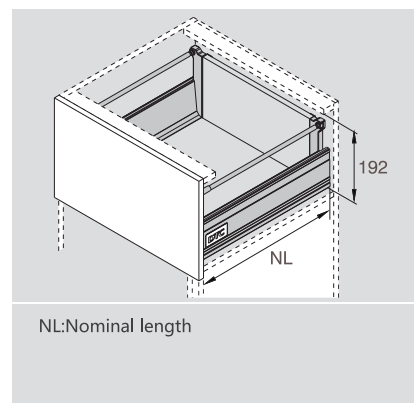

PLANNING

Installation Dimensions(mm)

NL=Nominal Slide Length
LT=Internal Cabinet Depth
LT=NL+3

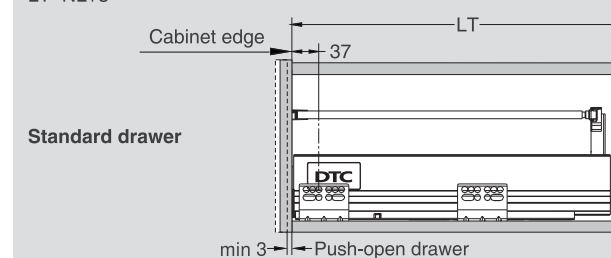

Cabinet Configuration

Cabinet widths/KB(mm)	Cabinet widths/KB(mm)	Stabilizer recommended
300		
350		
400		
450		
500		
600		
800	800	
900	900	
1000	1000	
1200	1200	

MEDIUM DRAWER WITH SINGLE ROUND RAILING FOR WOOD DRAWER BACK

Kit Package				1 Slides (left/right) /Industrial Package				2 Drawer Sides and Cover Caps (left/right) /Industrial Package			
White(E01) Silver Grey(E18) Stainless Steel(F04)				Pre-zinc Steel (F02)				White(E01) Silver Grey(E18) Stainless Steel(F04)			
NL	Soft Close item No.	Push-open item No.	Set /ctn	NL	Soft Close item No.	Push-open item No.	Set /ctn	NL	Item No.	Set/ctn	
400mm	M02400B	M32400B	1	400mm	M01400H	M31400H	5	400mm	M02400	5	
450mm	M02450B	M32450B	1	450mm	M01450H	M31450H	5	450mm	M02450	5	
500mm	M02500B	M32500B	1	500mm	M01500H	M31500H	5	500mm	M02500	5	
550mm	M02550B	M32550B	1	550mm	M01550H	M31550H	5	550mm	M02550	5	
600mm	M02600B	M32600B	1	600mm	M01600H	M31600H	5	600mm	M02600	5	

3 Back Fixing-brackets (left/right) /Industrial Package	
White(E01) Silver Grey(E18) Chrome Plated(C01)	
Item No.	M02032
Set/ctn	40

6 Round Side Rails (left/right) /Industrial Package		
White(E01) Silver Grey(E18) Chrome Plated(C01)		
NL	Item No.	Set/ctn
400mm	M01041400	60
450mm	M01041450	60
500mm	M01041500	60
550mm	M01041550	60
600mm	M01041600	60

4 Front Fixing-brackets (left/right) /Industrial Package	
Zinc Plated (B01)	
Item No.	Set/ctn
Screw-on M01011	120
Press-in M01016	120

5 Front Fixing-brackets /Industrial Package	
Grey(H11)	
Item No.	M02014
Set/ctn	120

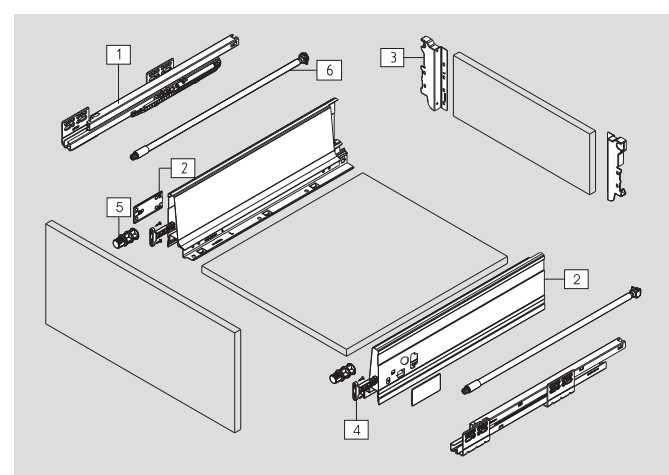

Screw Positions of the Slides(mm)

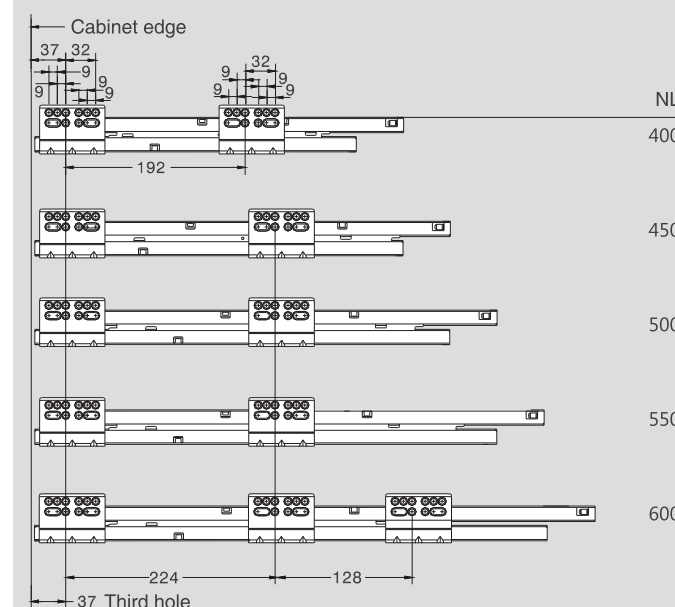

Installation Dimensions(mm)

LW=Internal Cabinet Width

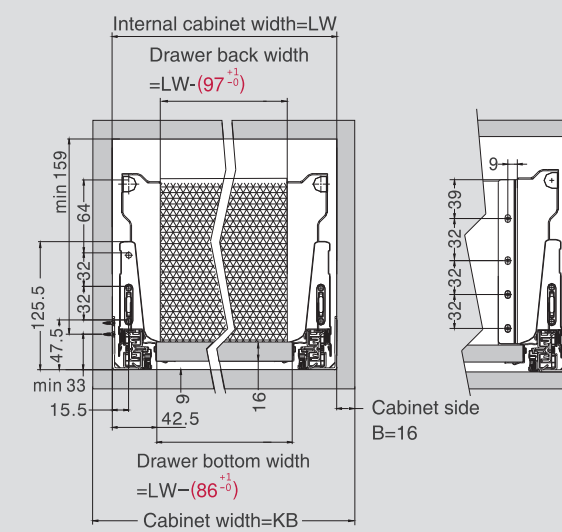

Drawer Front, Back and Bottom Dimensions(mm)

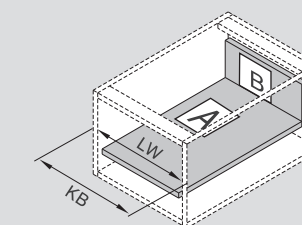
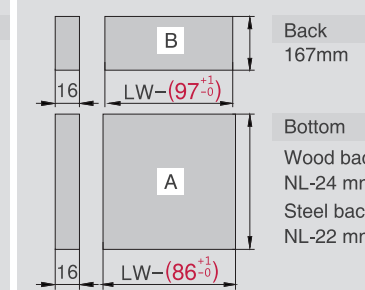
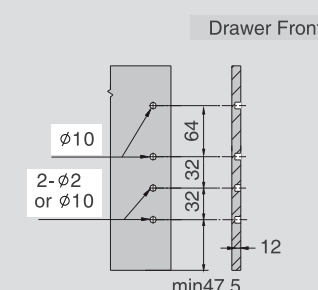

KB Cabinet width
LW Internal cabinet width
NL Nominal length

DOUBLE-WALL DRAWER

M02 Series Double-wall Drawer System
(C Height:Medium Inner Drawer)

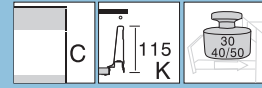

PRODUCT



DESCRIPTION

- Concealed, full extension
- Dynamic load capacity: 30/40/50kg
- Tool free assembly and removal of drawer
- Silent system guarantees smooth run without noise
- Up&down adjustment, left&right adjustment
- Finish:White(E01), silver grey(E18), stainless steel(F04)

SPACE REQUIREMENT

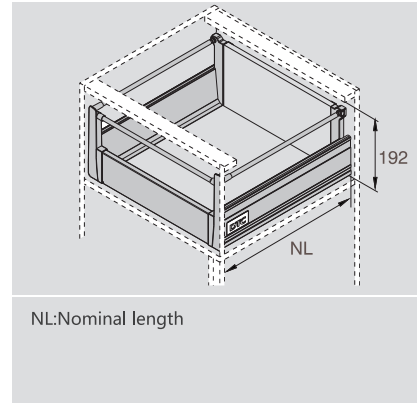

PLANNING

Installation Dimensions(mm)

NL=Nominal Slide Length
LT=Internal Cabinet Depth

Soft close slides LT=NL+3
Push-open slides LT=NL+12

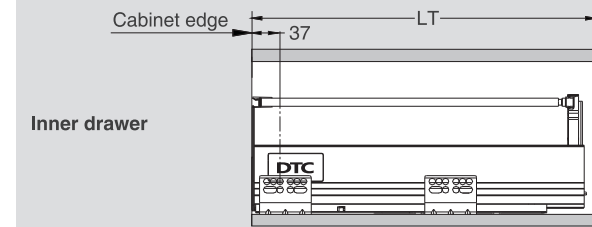

Cabinet Configuration

Cabinet widths/KB(mm)	Cabinet widths/KB(mm) Stabilizer recommended
300	
350	
400	
450	
500	
600	
800	800
900	900
1000	1000
1200	1200

MEDIUM INNER DRAWER WITH SINGLE ROUND RAILING FOR WOOD DRAWER BACK

Kit Package				1 Slides (left/right) /Industrial Package				2 Drawer Sides and Cover Caps (left/right) /Industrial Package			
White(E01)!Silver Grey(E18)!Stainless Steel(F04)				Pre-zinc Steel (F02)				White(E01)!Silver Grey(E18)!Stainless Steel(F04)			
NL	Soft Close item No.	Push-open item No.	Set /ctn	NL	Soft Close item No.	Push-open item No.	Set /ctn	NL	Item No.	Set/ctn	
400mm	M02400R	M32400R	1	400mm	M01400H	M31400H	5	400mm	M02400	5	
450mm	M02450R	M32450R	1	450mm	M01450H	M31450H	5	450mm	M02450	5	
500mm	M02500R	M32500R	1	500mm	M01500H	M31500H	5	500mm	M02500	5	
550mm	M02550R	M32550R	1	550mm	M01550H	M31550H	5	550mm	M02550	5	
600mm	M02600R	M32600R	1	600mm	M01600H	M31600H	5	600mm	M02600	5	

3 Back Fixing-brackets (left/right) / Industrial Package		
White(E01)!Silver Grey(E18)!Chrome Plated(C01)		
Item No.	Set/ctn	
M02032	40	

4 Front Fixing-brackets (left/right) / Industrial Package		
White(H03)!Grey(H11)		
Item No.	Set/ctn	
M02011	40	

5 Front Section / Industrial Package		
/For cutting to size,1100mm.		
Cutting:Internal cabinet width LW-97		
White(E01)!Silver Grey(E18)!		
Item No.	Pcs/ctn	
M01021	20	

6 Round Side Rails (left/right) /Industrial Package		
White(E01)!Silver Grey(E18)!Chrome Plated(C01)		
NL	Item No.	Set/ctn
400mm	M0104F400	60
450mm	M0104F450	60
500mm	M0104F500	60
550mm	M0104F550	60
600mm	M0104F600	60

7 Round Cross Rail		
/For cutting to size,1100mm.		
Cutting:Internal cabinet width LW-74		
White(E01)!Silver Grey(E18)!		
Item No.	Pcs/ctn	
M01043	120	

Front section and cross rail not included in the kit

Screw Positions of the Slides(mm)

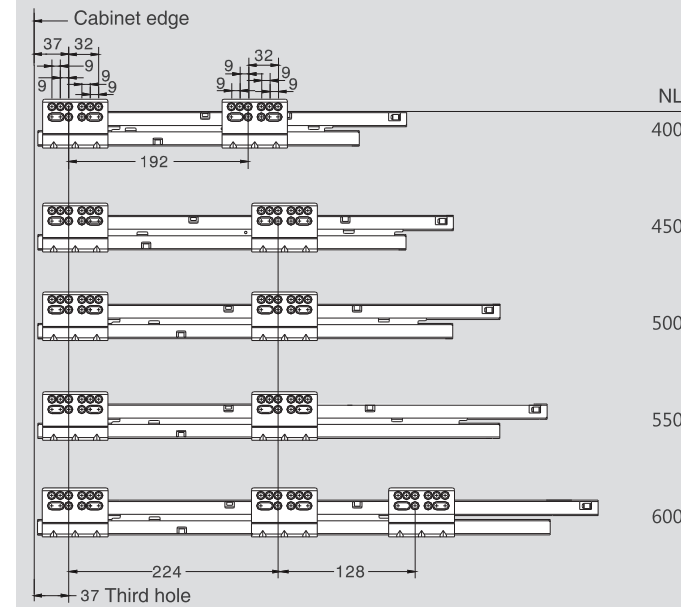

Fixing Hole Position for Push-open Inner Drawer(mm)

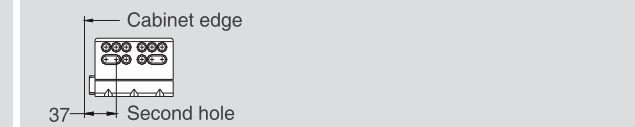

Installation Dimensions(mm)

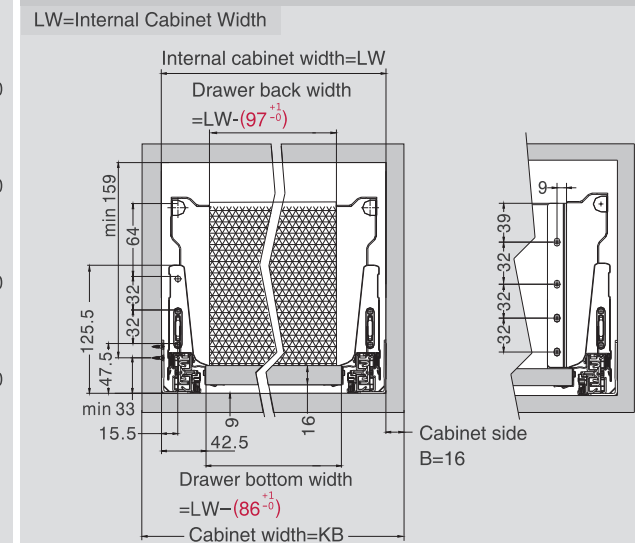

Drawer Front, Back and Bottom Dimensions(mm)

