



DOUBLE-WALL DRAWER SYSTEMS

MAGIC-STAR PLUS

# MAGIC-STAR PLUS

The Metal Straight-sided Slim Drawer

A Perfect Mix of Function and Elegance



- Linear slim drawer sides - a fashion look and elegant appearance
- Perfect connection between components makes a beautiful drawer



Quietness



Intelligence



Durability



Eco-Friendliness



# MAGIC-STAR PLUS

## HD13 Series Straight-sided Drawer System (High Inner Drawer: C Height)

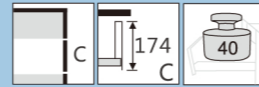

### PRODUCT



### DESCRIPTION

- Concealed, full extension
- Load capacity: 40kg
- Tool free assembly and removal of drawer
- Silent system guarantees smooth run without noise
- 2D adjustment: Up & down adjustment:  $\pm 2$ mm, left & right adjustment:  $\pm 1.5$ mm
- Finish: Silk white(E29), Grey matt(E30)

### SPACE REQUIREMENT

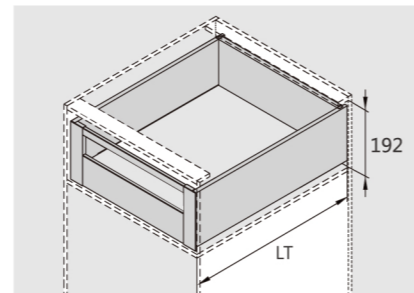

LT=Internal Cabinet Depth  
Soft close slides LT=NL+3  
Push-open slides LT=NL+13

### HIGH INNER DRAWER WITH SQUARE CROSS RAIL FOR WOOD DRAWER BACK

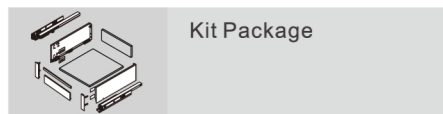

Kit Package			
Silk White(E29)! Grey Matt(E30)!			
NL	Soft Close item No.	Push-open item No.	Set/ctn
270mm	HD13270Q18	HD43270Q18	1
300mm	HD13300Q18	HD43300Q18	1
350mm	HD13350Q18	HD43350Q18	1
400mm	HD13400Q18	HD43400Q18	1
450mm	HD13450Q18	HD43450Q18	1
500mm	HD13500Q18	HD43500Q18	1
550mm	HD13550Q18	HD43550Q18	1
600mm	HD13600Q18	HD43600Q18	1



Pre-zinc Steel(F02)			
NL	Soft Close item No.	Push-open item No.	Set/ctn
270mm	HD10270H	HD40270H	5
300mm	HD10300H	HD40300H	5
350mm	HD10350H	HD40350H	5
400mm	HD10400H	HD40400H	5
450mm	HD10450H	HD40450H	5
500mm	HD10500H	HD40500H	5
550mm	HD10550H	HD40550H	5
600mm	HD10600H	HD40600H	5

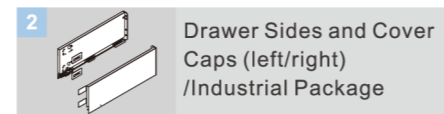

Silk White(E29)! Grey Matt(E30)!		
NL	Item No.	Set/ctn
270mm	HE132708	5
300mm	HE133008	5
350mm	HE133508	5
400mm	HE134008	5
450mm	HE134508	5
500mm	HE135008	5
550mm	HE135508	5
600mm	HE136008	5

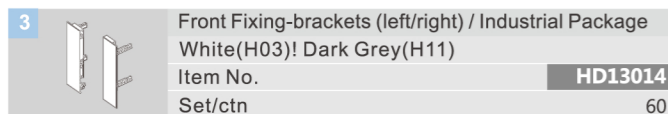

Front Fixing-brackets (left/right) / Industrial Package	
White(H03)! Dark Grey(H11)	
Item No.	Set/ctn
HD13014	60

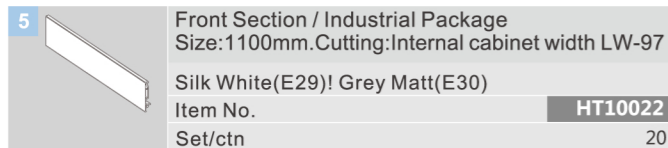

Front Section / Industrial Package	
Size:1100mm.Cutting:Internal cabinet width LW-97	
Silk White(E29)! Grey Matt(E30)	
Item No.	Set/ctn
HT10022	20

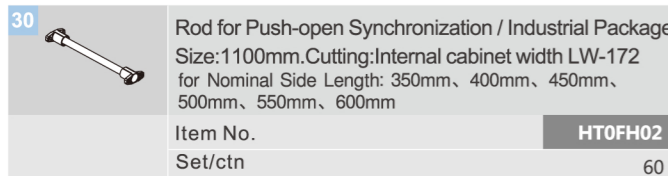

Rod for Push-open Synchronization / Industrial Package	
Size:1100mm.Cutting:Internal cabinet width LW-172 for Nominal Side Length: 350mm、400mm、450mm、500mm、550mm、600mm	
Item No.	Set/ctn
HT0FH02	60

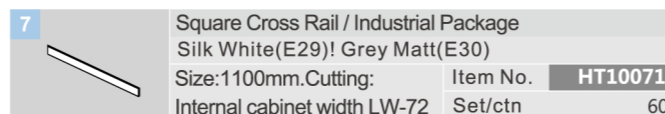

Square Cross Rail / Industrial Package	
Silk White(E29)! Grey Matt(E30)	
Size:1100mm.Cutting:	Item No.
Internal cabinet width LW-72	Set/ctn
HT10071	60

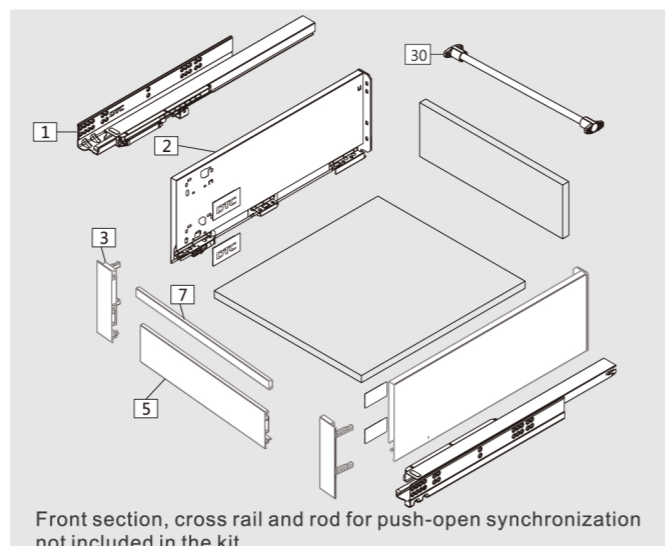

Front section, cross rail and rod for push-open synchronization not included in the kit

### PLANNING

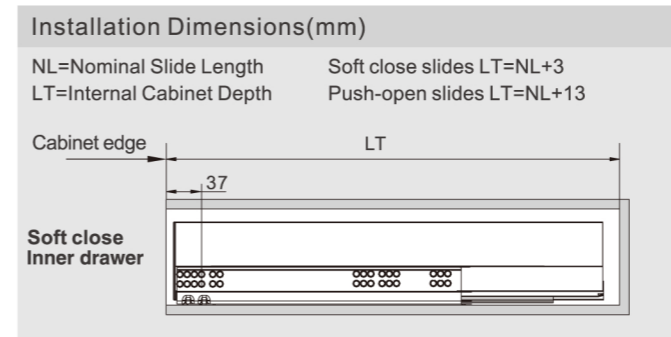

Cabinet Configuration	
Cabinet widths/KB(mm)	Push-open drawer Synchronization rod
300	○
350	○
400	○
450	○
500	○
600	○
800	●
900	●
1000	●
1200	●

○ recommended  
● strongly recommended

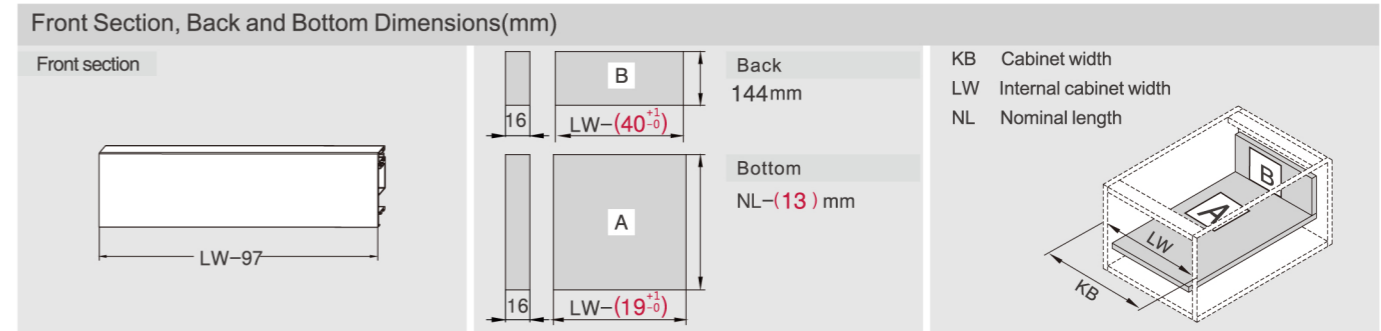
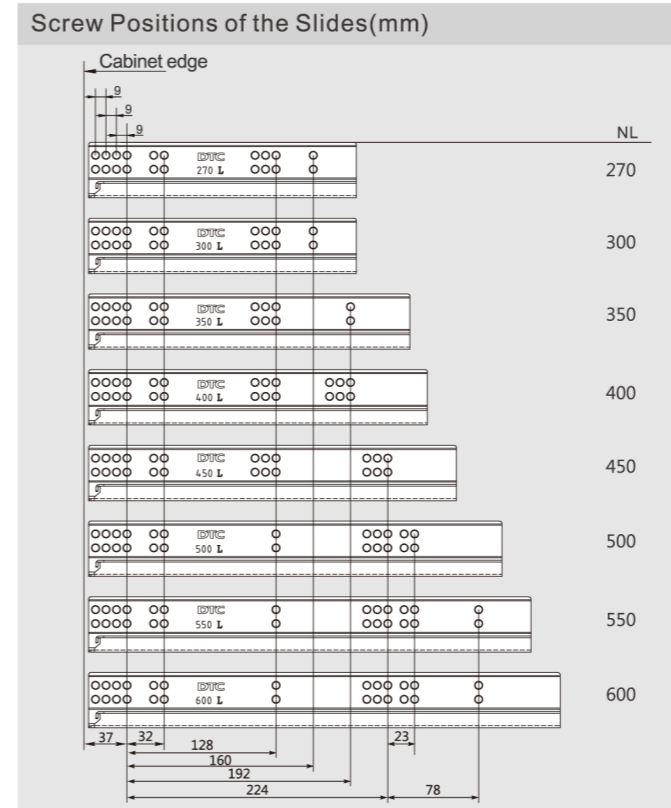
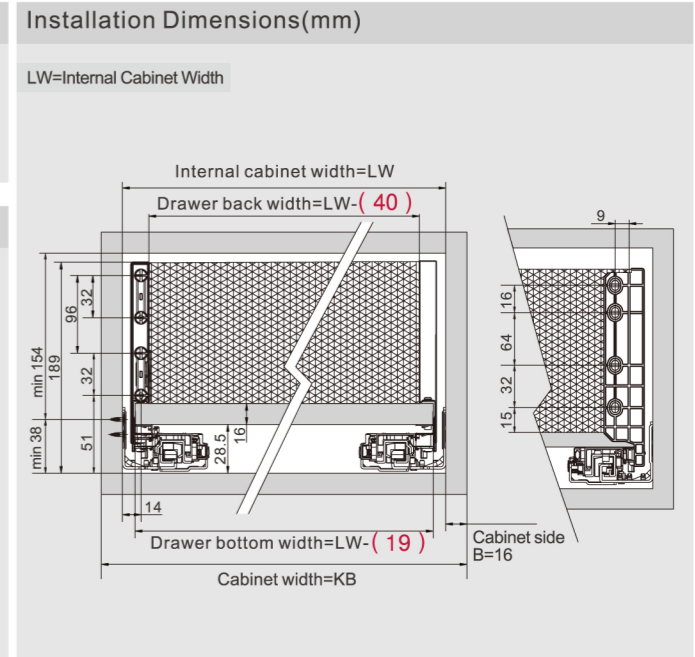
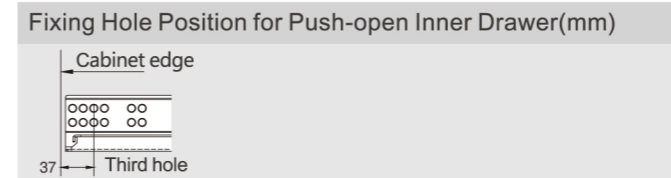

DOUBLE-WALL DRAWER SYSTEMS

# ASSEMBLY AND ADJUSTMENT

Assembly and Adjustment(for MAGIC-STAR PLUS)

